

# *Lecture 6: Water in Atmosphere*



- Indices of Water Vapor Content
- Adiabatic Process
- Lapse Rate and Stability



# Introduction

- ❑ Over 70% of the planet is covered by water
- ❑ Water is unique in that it can simultaneously exist in all three states (solid, liquid, gas) at the same temperature
- ❑ Water is able to shift between states very easily
- ❑ Important to global energy and water cycles



## How Much Water Is Evaporated Into the Atmosphere Each Year?

- ❑ On average, 1 meter of water is evaporated from oceans to the atmosphere each year.
- ❑ The global averaged precipitation is also about 1 meter per year.



# How Much Heat Is Brought Upward By Water Vapor?

- ❑ Earth's surface lost heat to the atmosphere when water is evaporated from oceans to the atmosphere.
- ❑ The evaporation of the 1m of water causes Earth's surface to lost 83 watts per square meter, almost half of the sunlight that reaches the surface.
- ❑ Without the evaporation process, the global surface temperature would be 67°C instead of the actual 15°C.



# Vertical Distribution of Energy

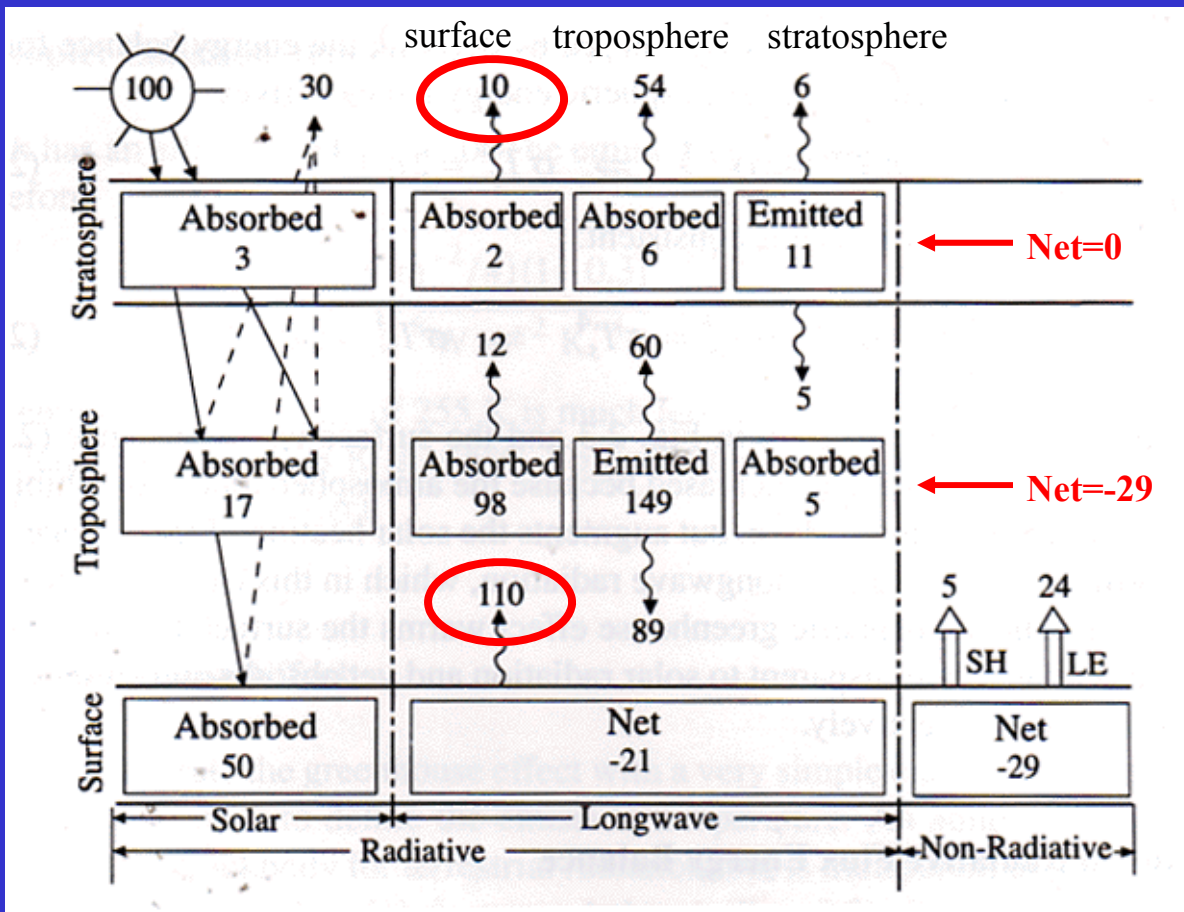

## Incoming solar energy (100)

- 70% absorbed
  - 50% by Earth's surface
  - 20% by atmosphere
  - 3% in stratosphere (by ozone and O<sub>2</sub>)
  - 17% in troposphere (water vapor & cloud)
- 30% reflected/scattered back
  - 20% by clouds
  - 6% by the atmosphere
  - 4% by surface

(from *Global Physical Climatology*)



# Phase Changes of Water

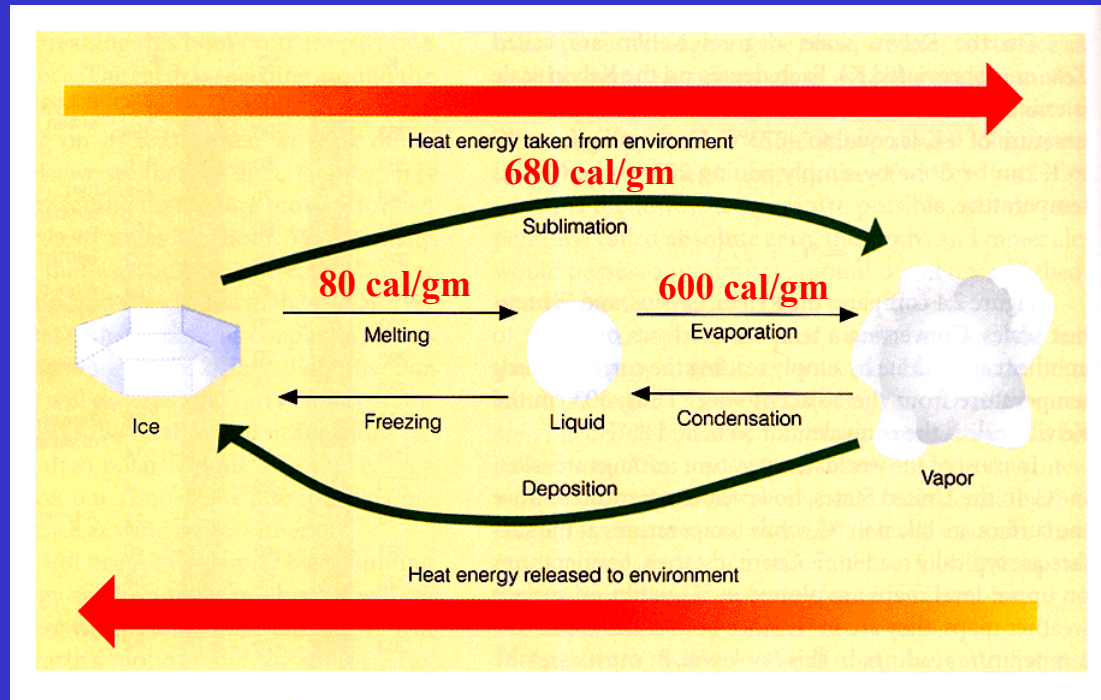

(from *Meteorology: Understanding the Atmosphere*)

- ❑ Latent heat is the heat released or absorbed per unit mass when water changes phase.
- ❑ Latent heating is an efficient way of transferring energy globally and is an important energy source for Earth's weather and climate.



# Water Vapor In the Air

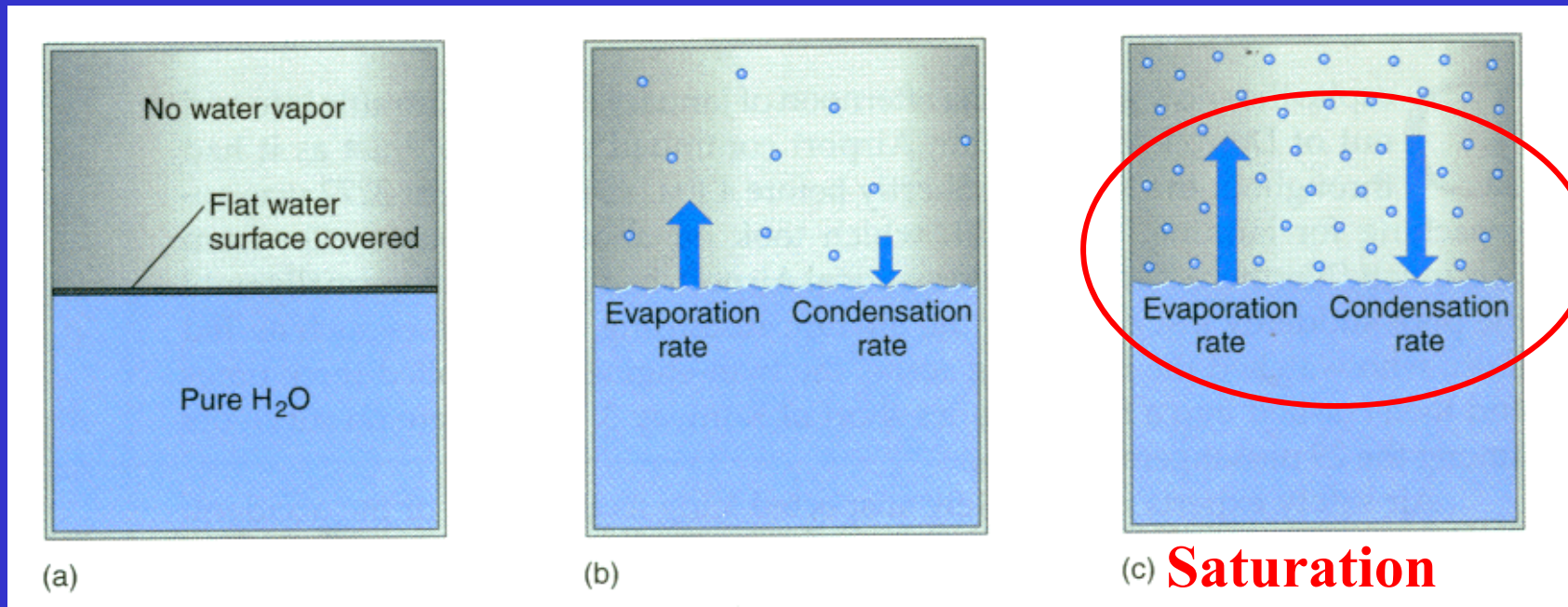

(from *Understanding Weather & Climate*)

- ❑ **Evaporation:** the process whereby molecules break free of the liquid volume.
- ❑ **Condensation:** water vapor molecules randomly collide with the water surface and bond with adjacent molecules.



# Indices of Water Vapor Content

☐ by mass

$$\text{Mixing ratio} = \frac{\text{mass of water vapor}}{\text{mass of dry air}}$$

$$\text{Specific humidity} = \frac{\text{mass of water vapor}}{\text{total mass of air}}$$

$$\text{Absolute humidity} = \frac{\text{mass of water vapor}}{\text{volume of air}}$$

in unit of g/kg

in unit of g/m<sup>3</sup>

☐ by vapor pressure

$$\text{RH} = \frac{\text{actual vapor pressure}}{\text{saturation vapor pressure}} \times 100 \text{ percent.}$$

relative  
humidity

$$\text{RH} = \frac{\text{actual mixing ratio}}{\text{saturation mixing ratio}} \times 100 \text{ percent.}$$

in unit of %

☐ by temperature → Dew Point Temperature





# Observed Specific Humidity

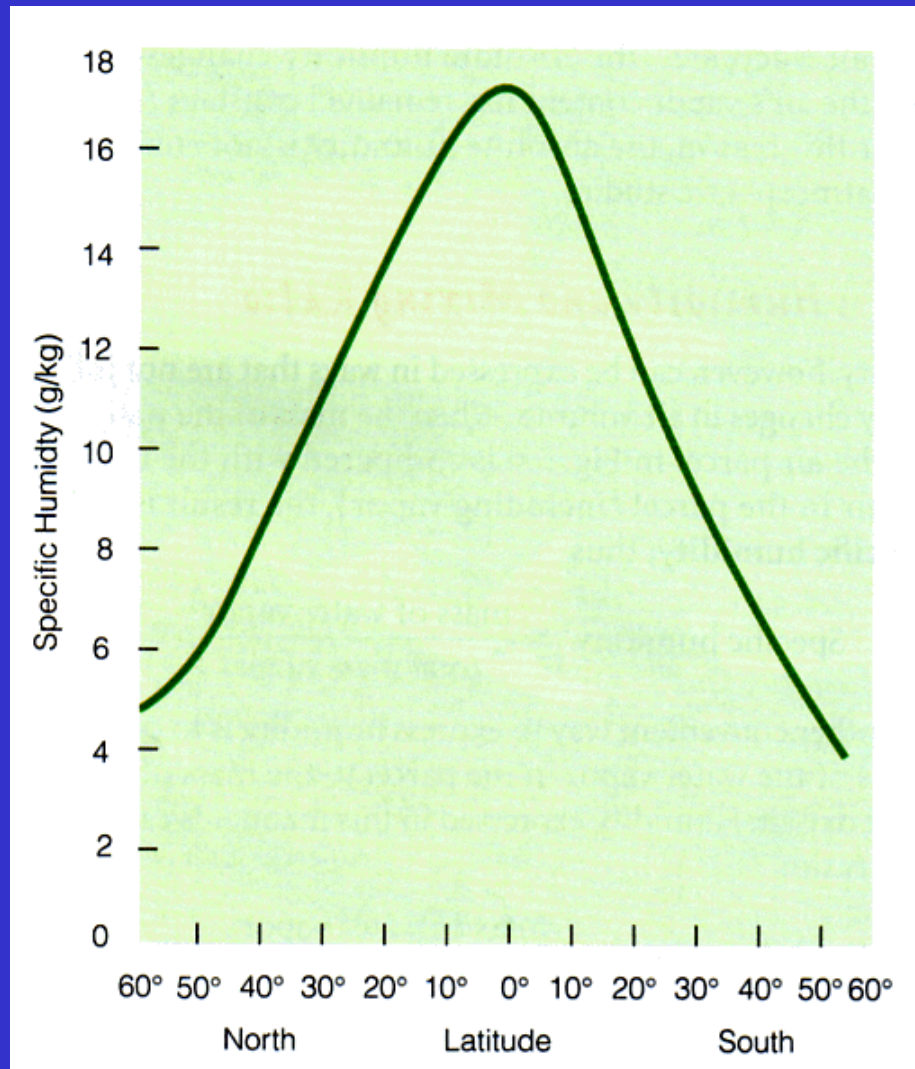

(from *Meteorology Today*)



# Vapor Pressure

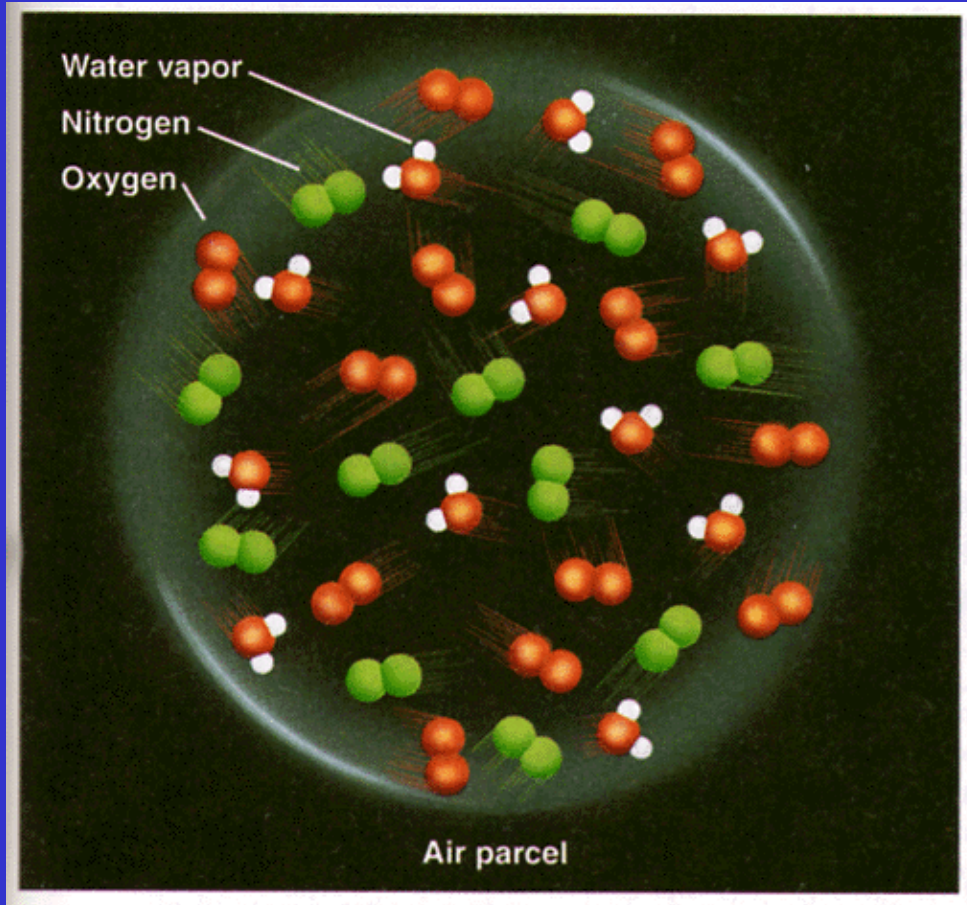

(from *Meteorology Today*)

- ❑ The air's content of moisture can be measured by the pressure exerted by the water vapor in the air.
- ❑ The total pressure inside an air parcel is equal to the sum of pressures of the individual gases.
- ❑ In the left figure, the total pressure of the air parcel is equal to sum of vapor pressure plus the pressures exerted by Nitrogen and Oxygen.
- ❑ High vapor pressure indicates large numbers of water vapor molecules.
- ❑ Unit of vapor pressure is usually in mb.



# Saturation Vapor Pressure

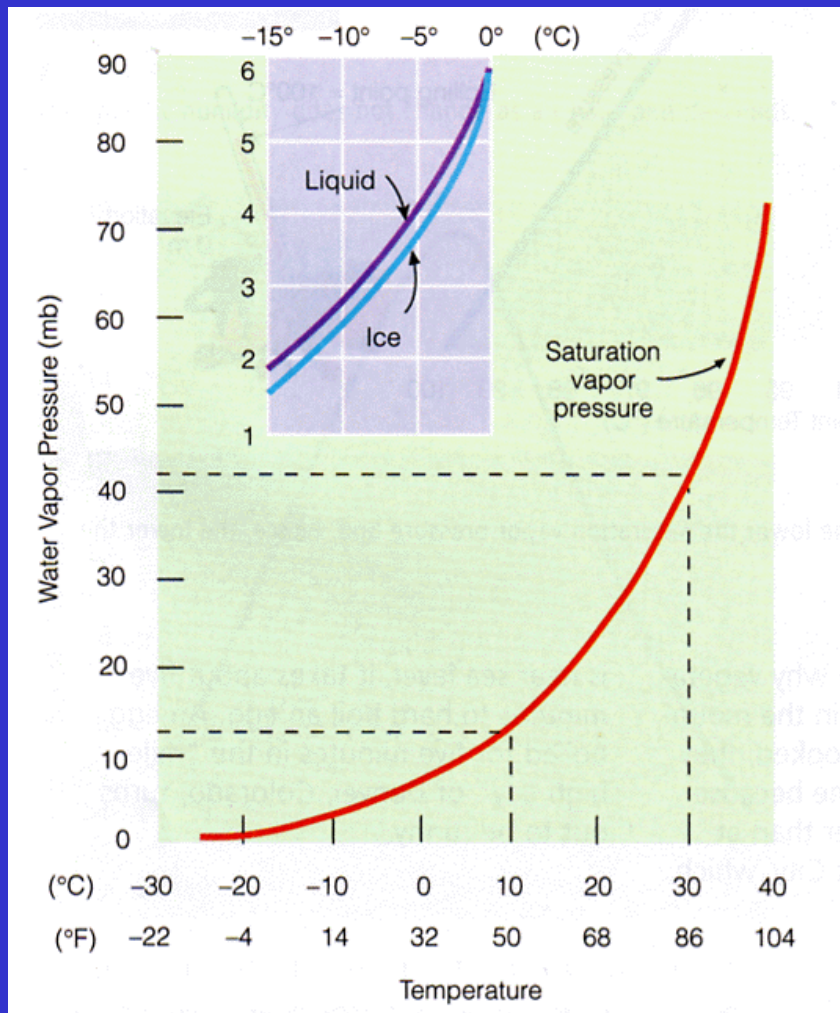

- Saturation vapor pressure describes how much water vapor is needed to make the air saturated at any given temperature.
- Saturation vapor pressure depends primarily on the air temperature in the following way:

$$\frac{de_s}{dT} = \frac{L}{T(\alpha_v - \alpha_l)}$$

**The  
Clausius-Clapeyron  
Equation**



$$e_s \cong 6.11 \cdot \exp \left\{ \frac{L}{R_v} \left( \frac{1}{273} - \frac{1}{T} \right) \right\}$$

- Saturation pressure increases exponentially with air temperature.

L: latent heat of evaporation;  $\alpha$ : specific volume of vapor and liquid



ESS55  
Prof. Jin-Yi Yu

# Composition of the Atmosphere (inside the DRY homosphere)

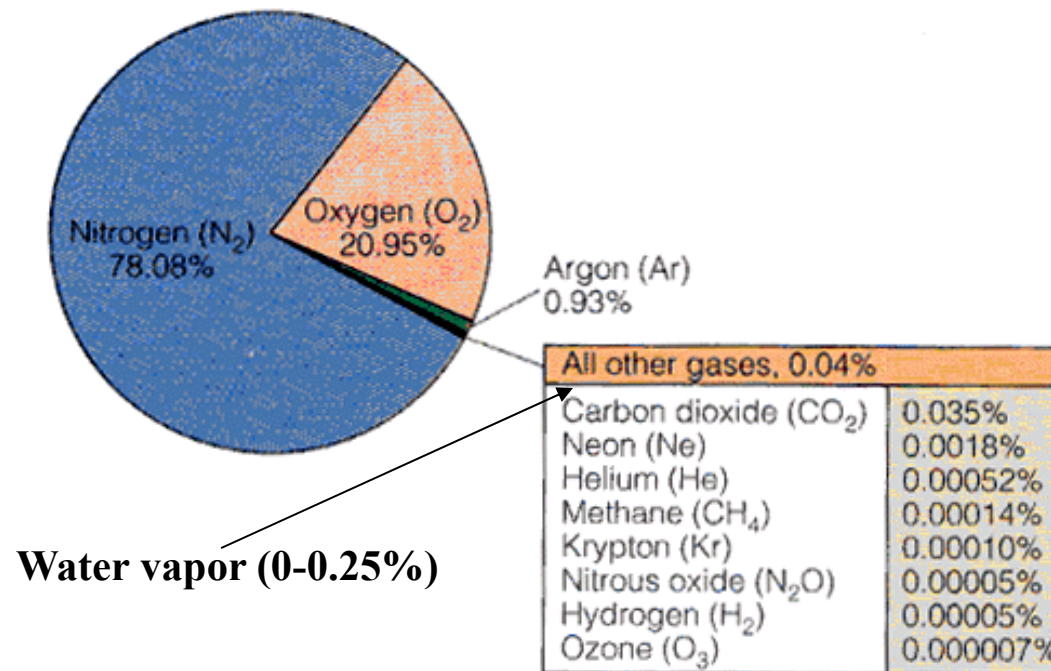

*Figure 12.2* Composition of dry, aerosol-free air in volume percent. Three gases—nitrogen, oxygen, and argon—make up 99.96 percent of the air.

(from *The Blue Planet*)



ESS55  
Prof. Jin-Yi Yu

# Specific .vs. Relative Humidity

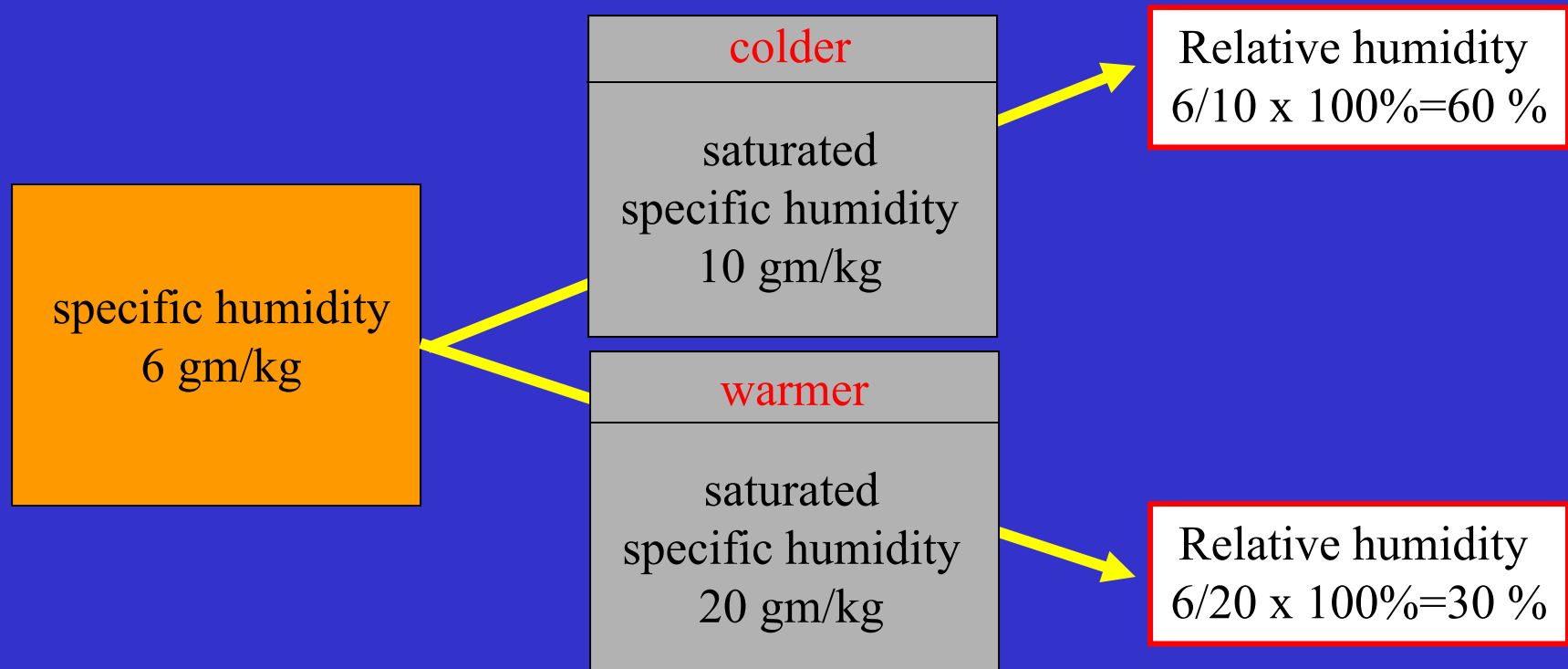

- ❑ Specific Humidity: How many grams of water vapor in one kilogram of air (in unit of gm/kg).
- ❑ Relative Humidity: The percentage of current moisture content to the saturated moisture amount (in unit of %).
- ❑ Clouds form when the relative humidity reaches 100%.



# How to Saturate the Air?

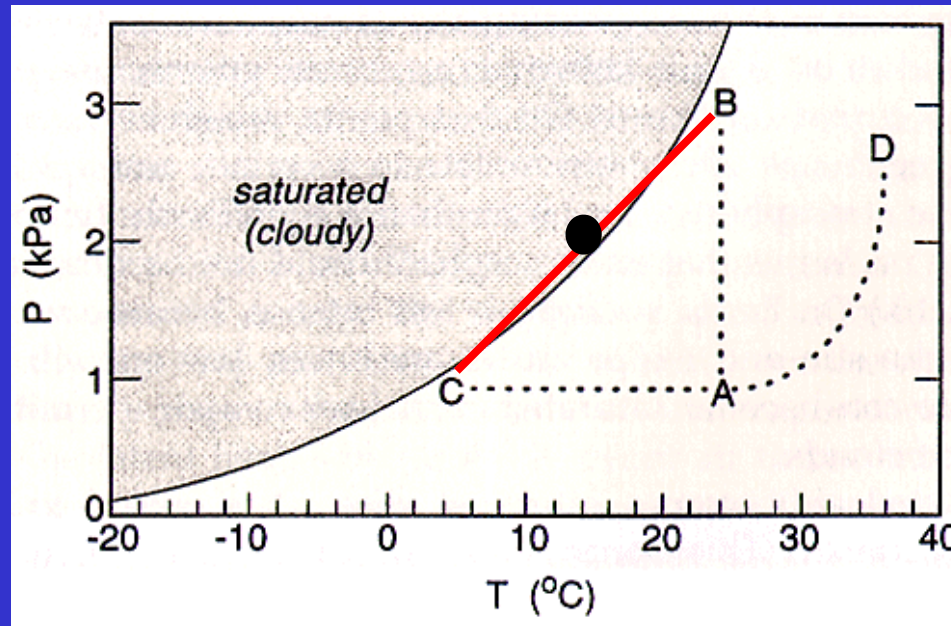

(from "IS The Temperature Rising")

□ Three ways:

- (1) Increase (inject more) water vapor to the air ( $A \rightarrow B$ ).
- (2) Reduce the temperature of the air ( $A \rightarrow C$ ).
- (3) Mix cold air with warm, moist air.



# Dew Point Temperature

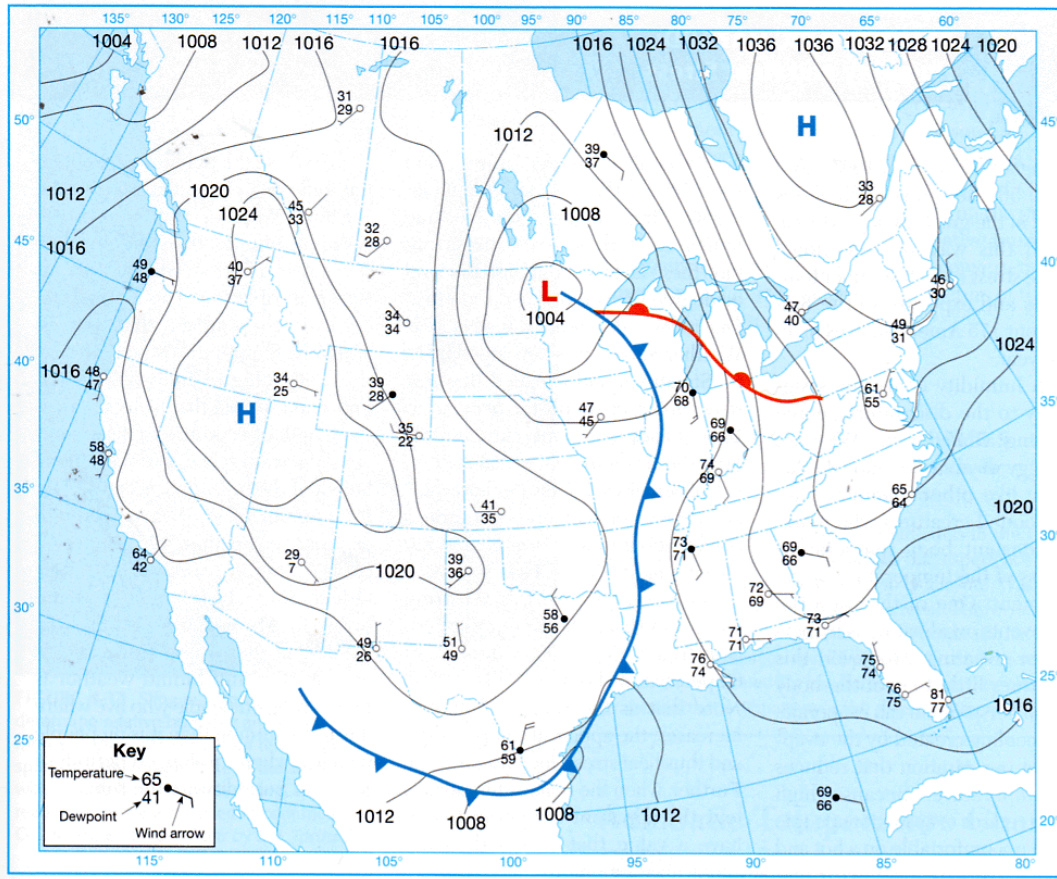

(from *The Atmosphere*)

- ❑ Dew point temperature is another measurement of air moisture.
- ❑ Dew point temperature is defined as the temperature to which moist air must be cooled to become saturated without changing the pressure.
- ❑ The closer the dew point temperature is to the air temperature, the closer the air is to saturation.
- ❑ Dew points can be only equal or less than air temperatures.



# Frost Point Temperature

- When air reaches saturation at temperatures below freezing the term *frost point* is used.





# Measuring Humidity

- ❑ The easiest way to measure humidity is through use of a *sling psychrometer* - A pair of thermometers one of which has a wetted cotton wick attached to the bulb.
- ❑ The two thermometers measure the wet and dry bulb temperature.
- ❑ Swinging the psychrometer causes air to circulate about the bulbs.
- ❑ When air is unsaturated, evaporation occurs from the wet bulb which cools the bulb.
- ❑ Once evaporation occurs, the wet bulb temperature stabilizes allowing for comparison with the dry bulb temperature.
- ❑ The wet bulb depression is found with a greater depression indicative of a dry atmosphere.
- ❑ Charts gauge the amount of atmospheric humidity.
- ❑ *Aspirated* and *hair hygrometers* are alternatives.



# Sling Psychrometer

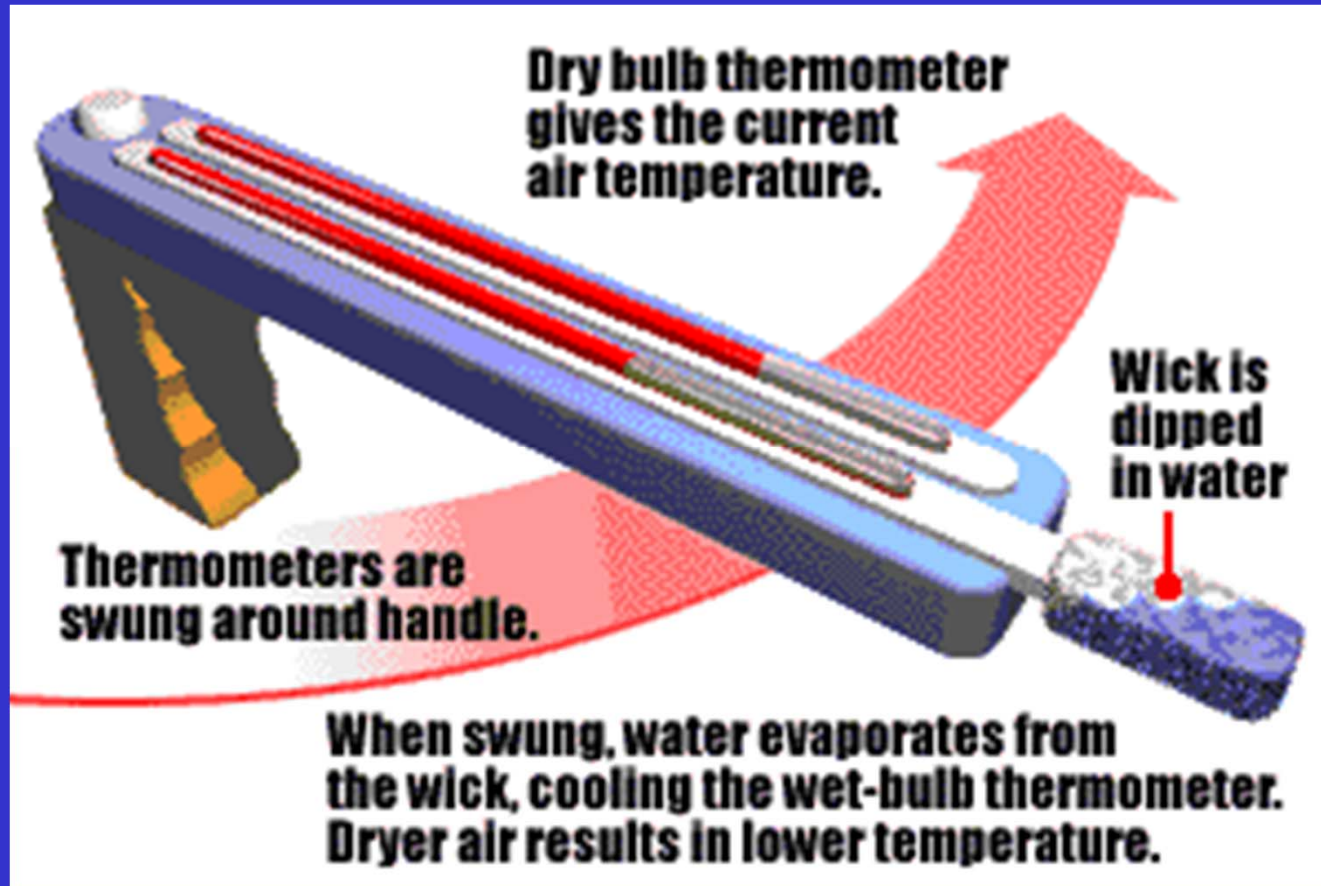

(from USA Today )



# Hair Hygrometers

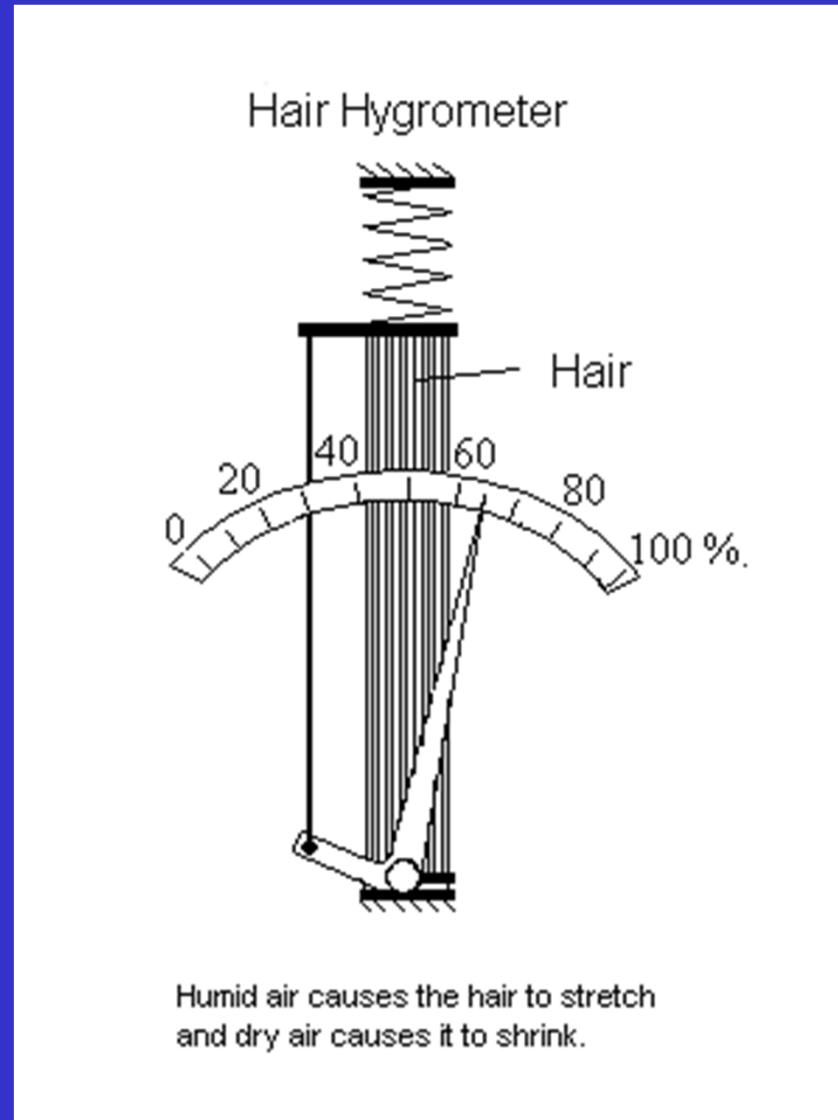

(from <http://de.wikipedia.org>)



ESS55  
Prof. Jin-Yi Yu

# Dew



(a)

❑ Liquid condensation on surface objects.

❑ Diabatic cooling of surface air typically takes place through terrestrial radiation loss on calm, cool, clear nights.



# Frost



(b)

□ Similar to dew except that it forms when surface temperatures are below freezing.

□ Deposition occurs instead of condensation.



# Fog

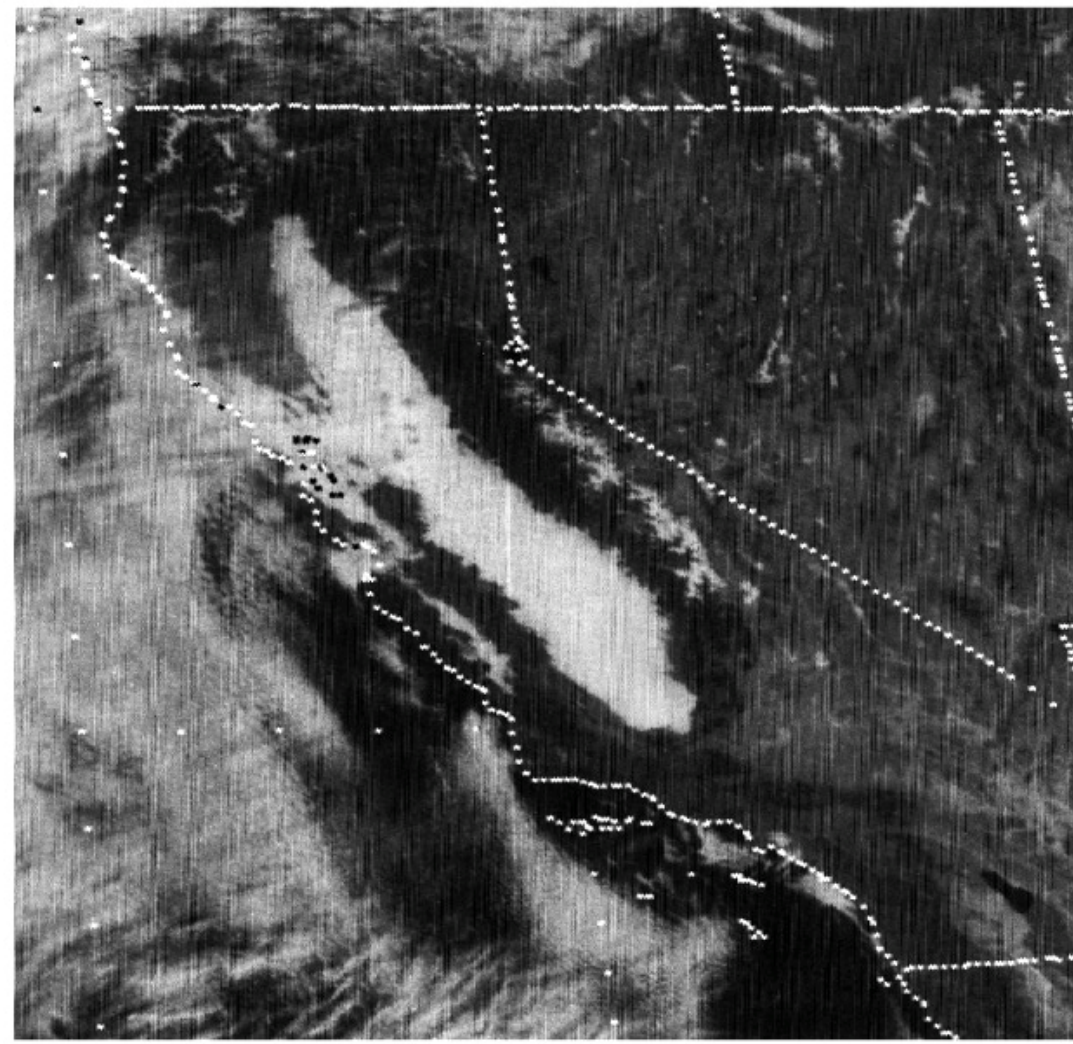

- Simply a surface cloud
- Fog formed when air either (1) cools to the dew point,
- (2) has moisture added, or
- (3) when cooler air is mixed with warmer moister air.



# How to Saturate the Air?

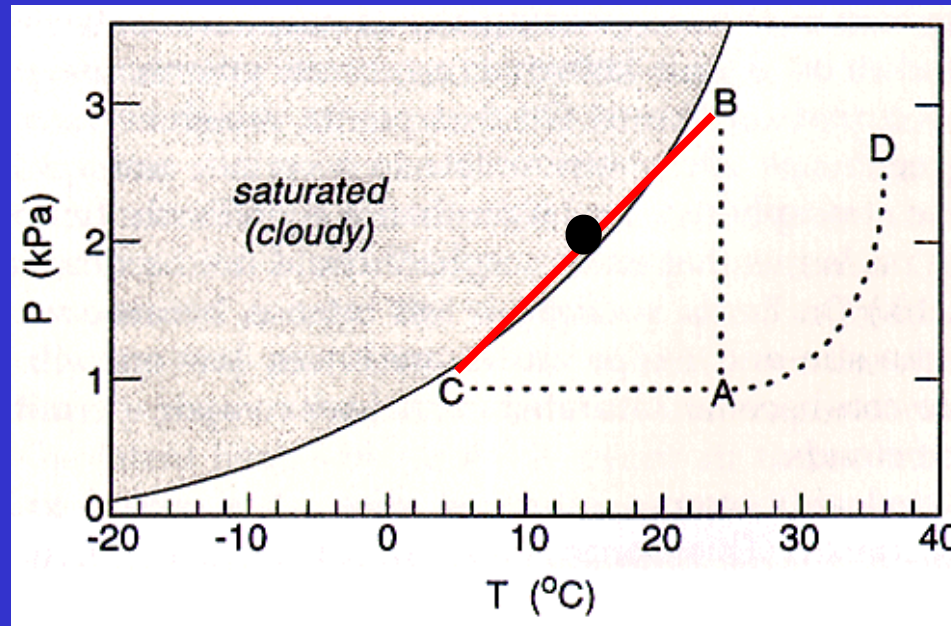

(from "IS The Temperature Rising")

□ Three ways:

- (1) Increase (inject more) water vapor to the air ( $A \rightarrow B$ ).
- (2) Reduce the temperature of the air ( $A \rightarrow C$ ).
- (3) Mix cold air with warm, moist air.



# Four Types of Fog

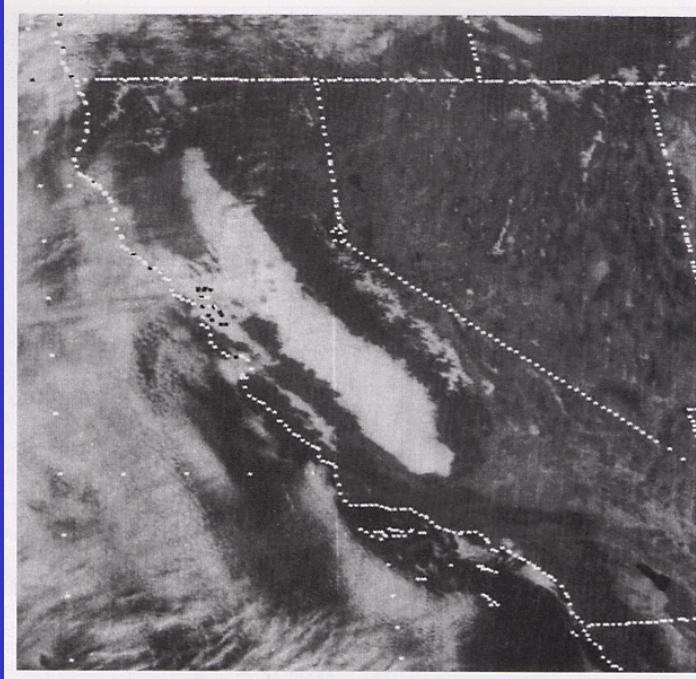

- Radiation Fog: radiation cooling → condensation → fog
- Advection fog: warm air advected over a cold surface → fog
- Upslope fog: air rises over a mountain barrier → air expands and cools → fog
- Evaporation fog: form over lake when colder air moves over warmer water → steam fog

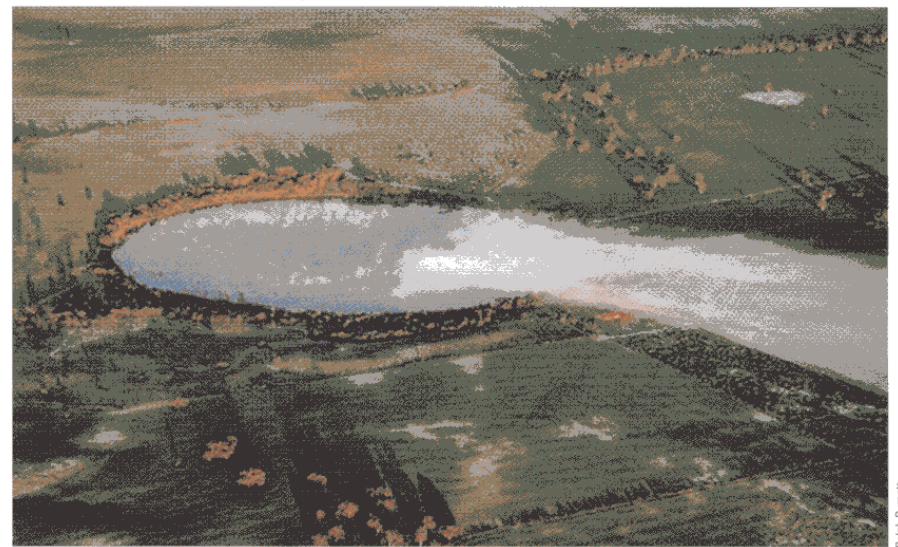

■ Figure 4.12

An aerial view of steam fog rising and moving downwind from a small lake in Australia. Using your knowledge of relative humidity plus the shadows in this photograph, can you determine what time of day this picture was taken?



# Different types of fog found throughout the U.S.: Radiation, advection, upslope, and evaporation fogs



# How to Saturate the Air?

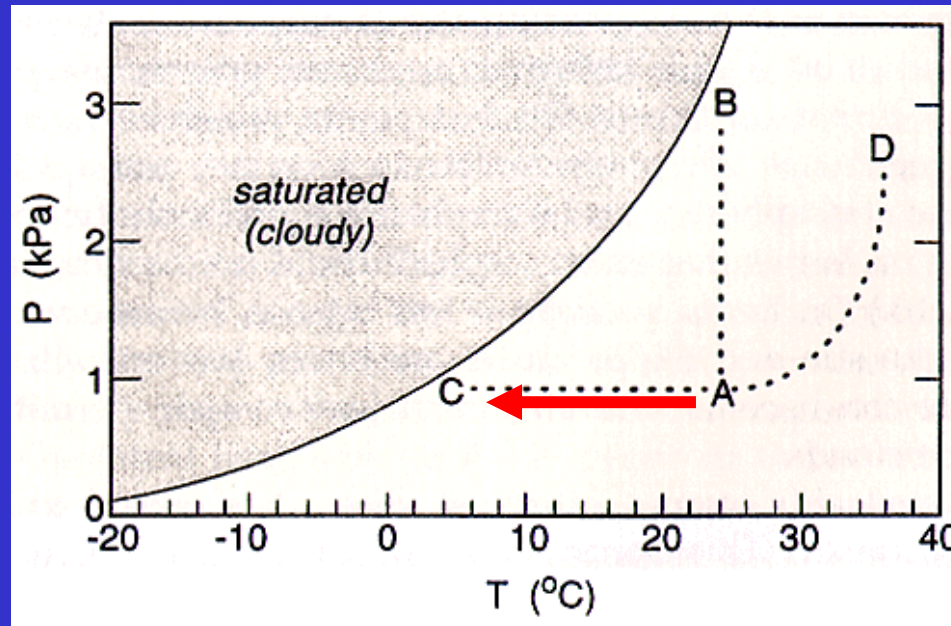

(from "IS The Temperature Rising")

□ Three ways:

- (1) Increase (inject more) water vapor to the air ( $A \rightarrow B$ ).
- (2) Reduce the temperature of the air ( $A \rightarrow C$ ).
- (3) Mix cold air with warm, moist air.



# The First Law of Thermodynamics

- This law states that (1) heat is a form of energy that (2) its conversion into other forms of energy is such that total energy is conserved.
- The change in the internal energy of a system is equal to the heat added to the system minus the work done by the system:

$$\Delta U = Q - W$$

change in internal energy  
(related to temperature)

Heat added to the system

Work done by the system



# Adiabatic Process

- If a material changes its state (pressure, volume, or temperature) without any heat being added to it or withdrawn from it, the change is said to be adiabatic.
- The adiabatic process often occurs when air rises or descends and is an important process in the atmosphere.



# Diabatic Process

- ❑ Involve the direct addition or removal of heat energy.
- ❑ Example: Air passing over a cool surface loses energy through conduction.



# Air Parcel Expands As It Rises...

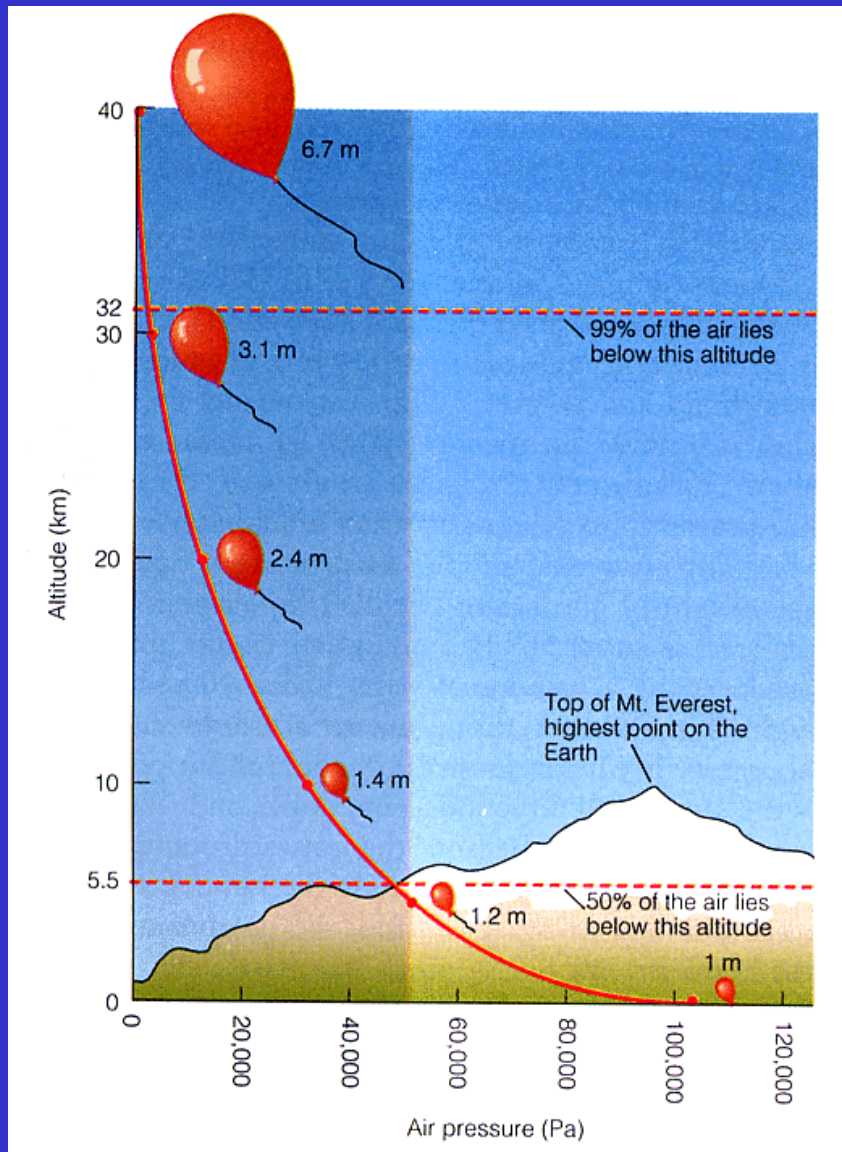

(from *The Blue Planet*)

- ❑ Air pressure decreases with elevation.
- ❑ If a helium balloon 1 m in diameter is released at sea level, it expands as it floats upward because of the pressure decrease. The balloon would be 6.7 m in diameter as a height of 40 km.



# What Happens to the Temperature?

- ❑ Air molecules in the parcel (or the balloon) have to use their kinetic energy to expand the parcel/balloon.
- ❑ Therefore, the molecules lost energy and slow down their motions
  - ➔ The temperature of the air parcel (or balloon) decreases with elevation. The lost energy is used to increase the potential energy of air molecular.
- ❑ Similarly when the air parcel descends, the potential energy of air molecular is converted back to kinetic energy.
  - ➔ Air temperature rises.



# Dry Adiabatic Lapse Rate

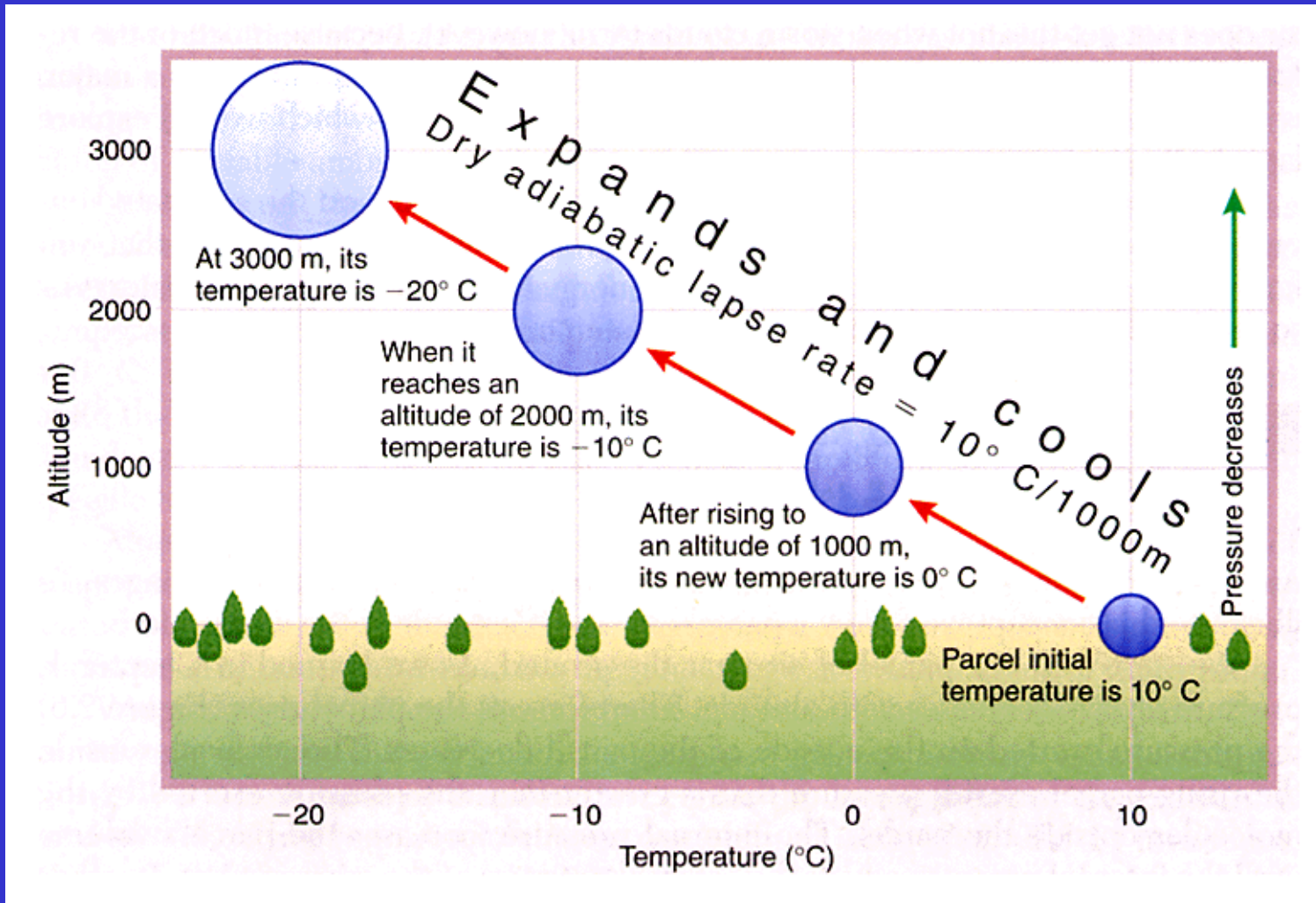

(from *Meteorology: Understanding the Atmosphere*)



ESS55  
Prof. Jin-Yi Yu



# Moist Adiabatic Lapse Rate

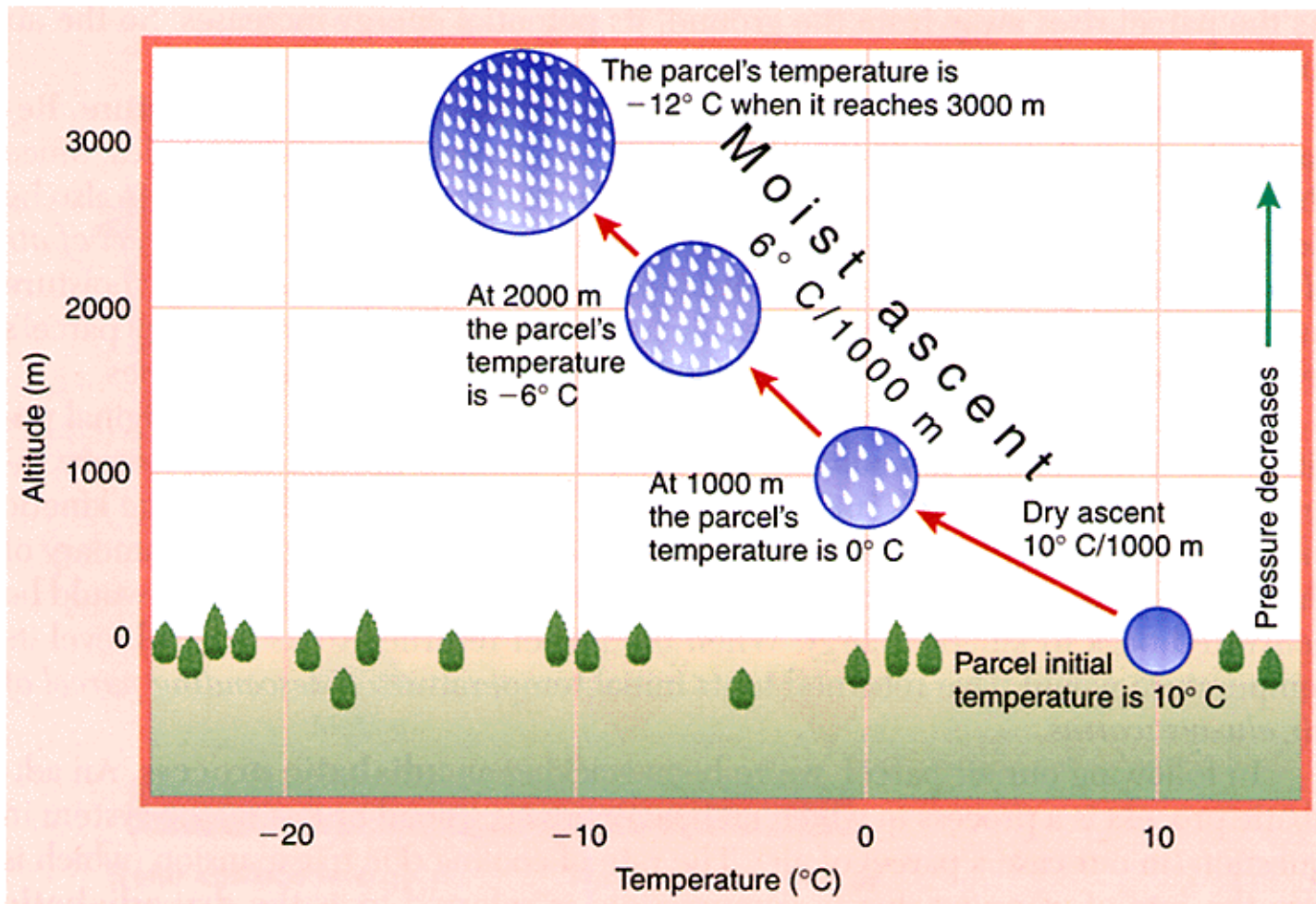

(from *Meteorology: Understanding the Atmosphere*)



# Dry and Moist Adiabatic Lapse Rates

- ❑ Dry adiabatic lapse rate is constant =  $10^{\circ}\text{C}/\text{km}$ .
  - ❑ Moist adiabatic lapse rate is NOT a constant. It depends on the temperature of saturated air parcel.
  - ❑ The higher the air temperature, the smaller the moist adiabatic lapse rate.
- ➔ When warm, saturated air cools, it causes more condensation (and more latent heat release) than for cold, saturated air.



# Static Stability

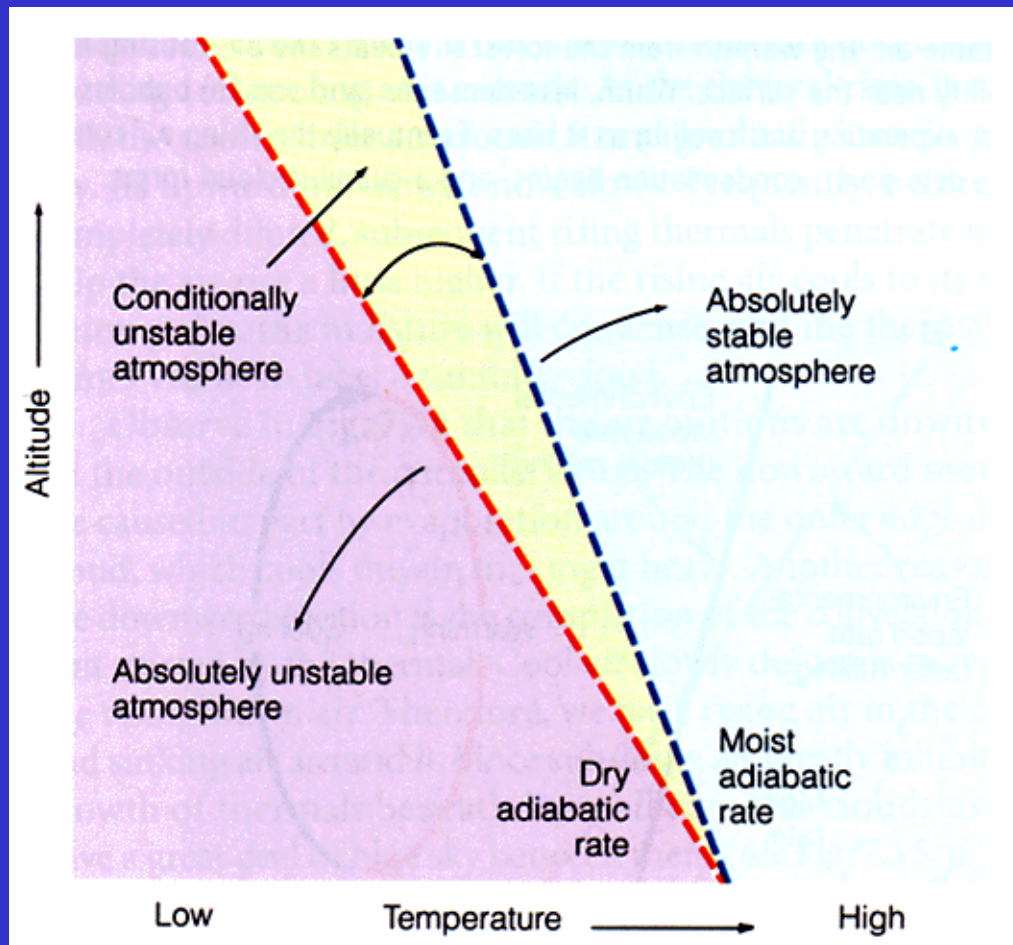

(from *Meteorology Today*)

- ❑ Static stability is referred as to air's susceptibility to uplift.
- ❑ The static stability of the atmosphere is related to the vertical structure of atmospheric temperature.
- ❑ To determine the static stability, we need to compare the lapse rate of the atmosphere (environmental lapse rate) and the dry (moist) adiabatic lapse rate of an dry (moist) air parcel.



# Concept of Stability

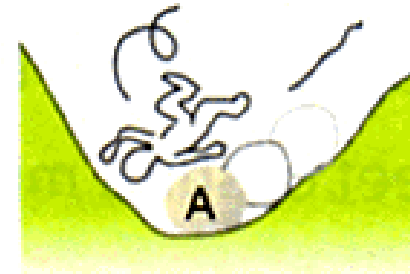
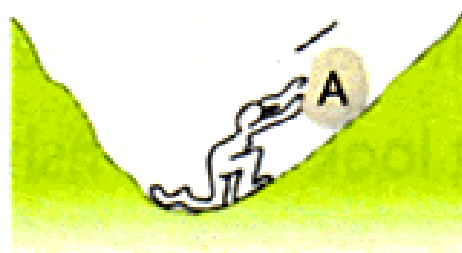
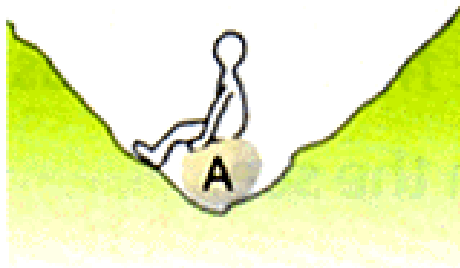

Stable equilibrium

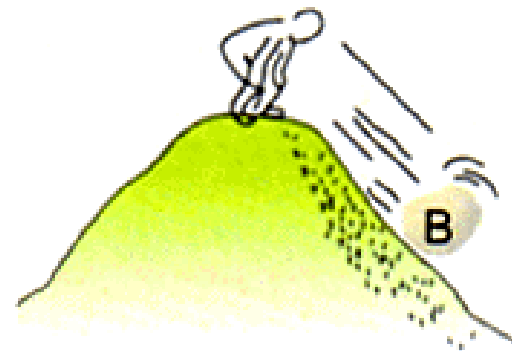
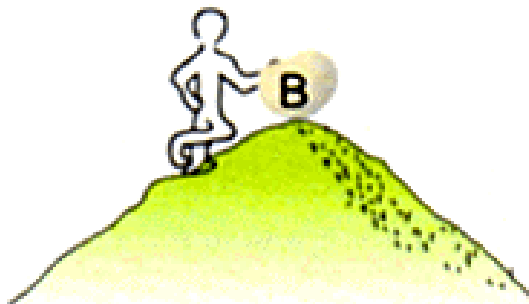

Unstable equilibrium

(from *Meteorology Today*)



# Environmental Lapse Rate

- The environmental lapse rate is referred to as the rate at which the air temperature surrounding us would be changed if we were to climb upward into the atmosphere.
- This rate varies from time to time and from place to place.



# Static Stability of the Atmosphere

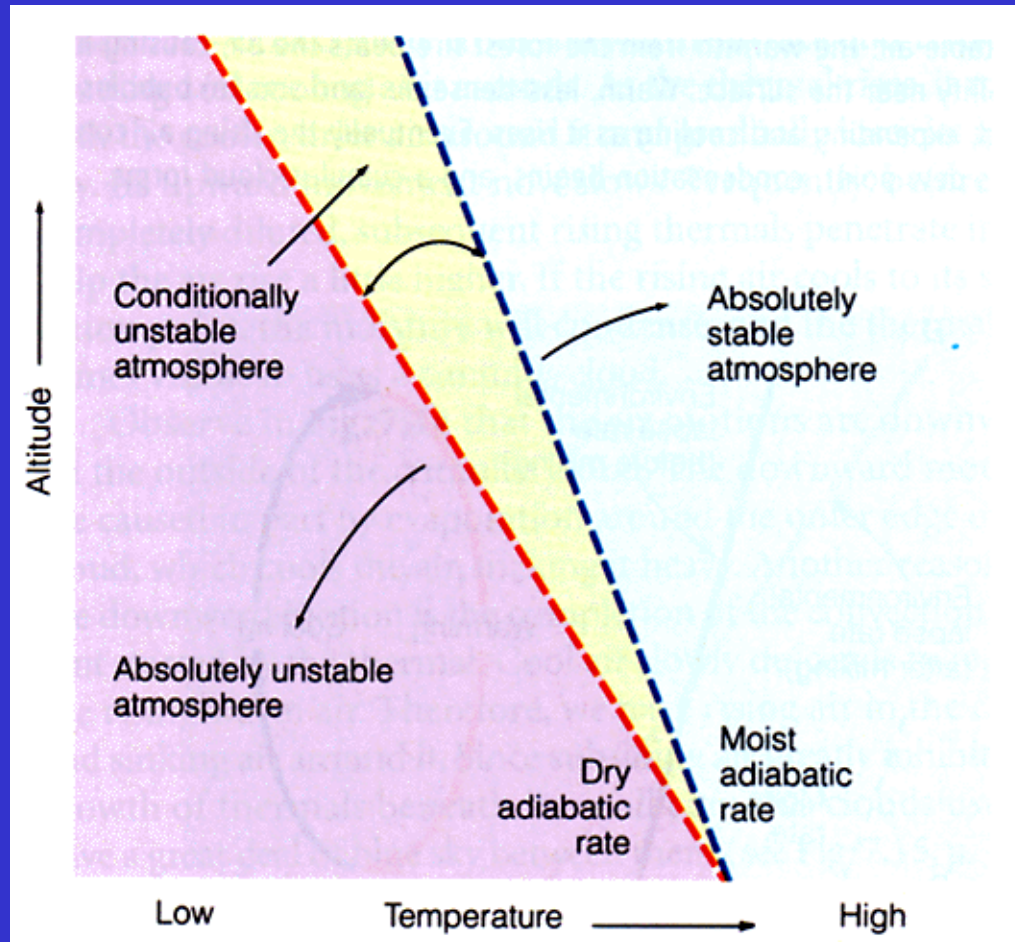

(from *Meteorology Today*)

$\Gamma_e$  = environmental lapse rate  
 $\Gamma_d$  = dry adiabatic lapse rate  
 $\Gamma_m$  = moist adiabatic lapse rate

Absolutely Stable

$$\Gamma_e < \Gamma_m$$

Absolutely Unstable

$$\Gamma_e > \Gamma_d$$

Conditionally Unstable

$$\Gamma_m < \Gamma_e < \Gamma_d$$



# Absolutely Stable Atmosphere

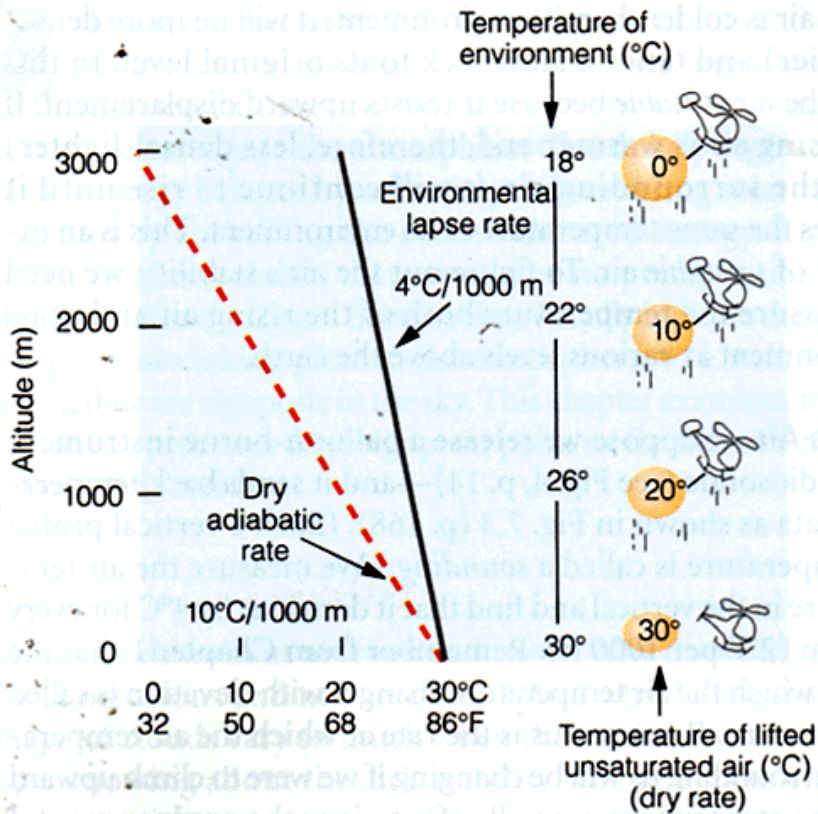

(a) Lifted, unsaturated air at each level is colder and heavier than the air around it. If given the chance, the parcel would return to its original position.

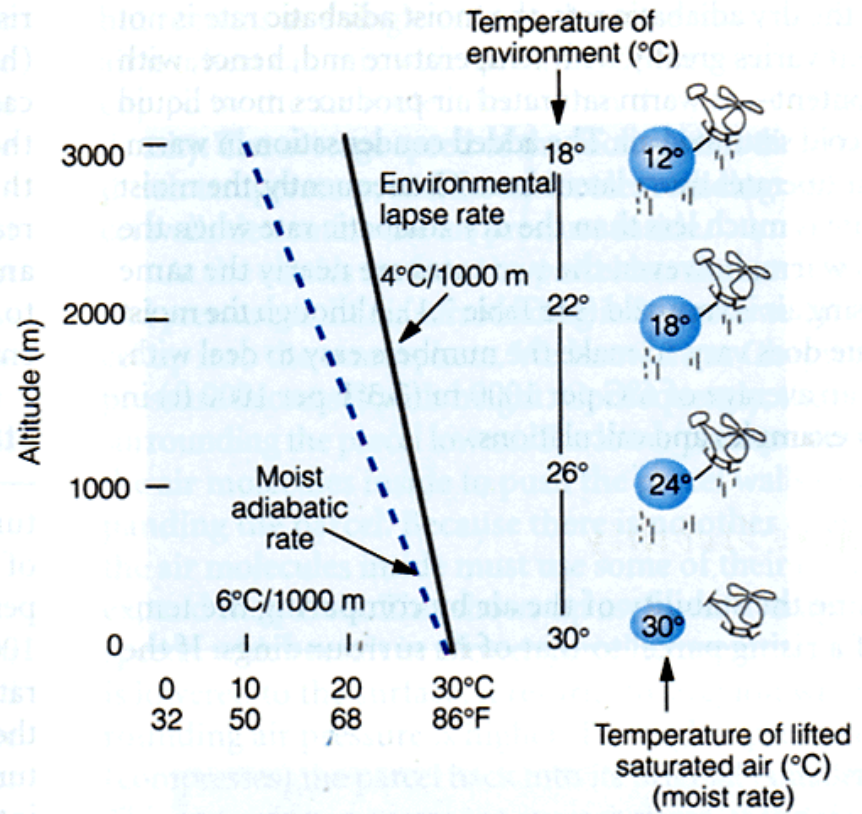

(b) Lifted, saturated air at each position is colder and heavier than the air surrounding it. If released, the parcel would return to its original position.

(from *Meteorology Today*)



ESS55  
Prof. Jin-Yi Yu

# Absolutely Unstable Atmosphere

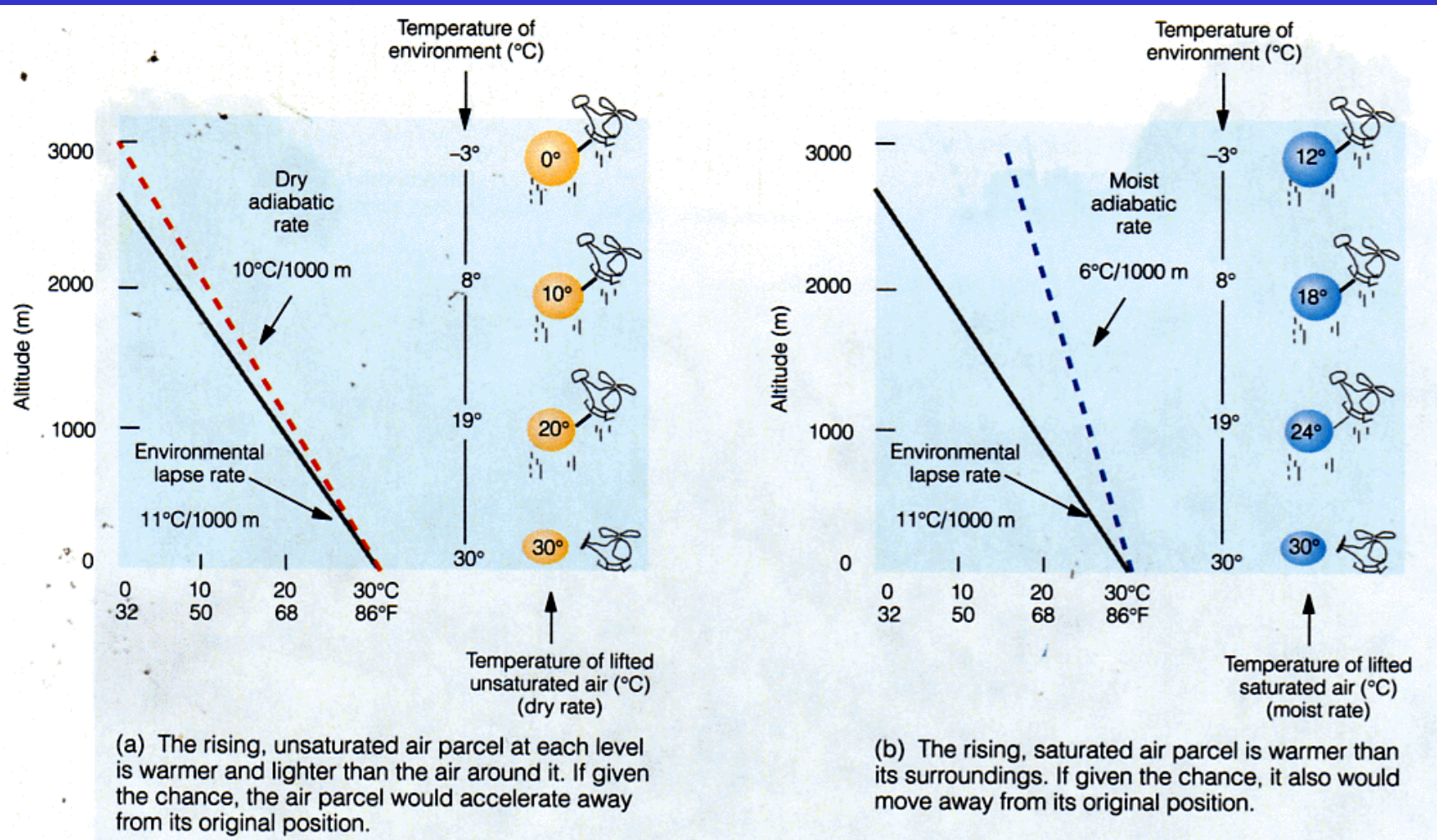

(from *Meteorology Today*)



ESS55  
Prof. Jin-Yi Yu



# Conditionally Unstable Atmosphere

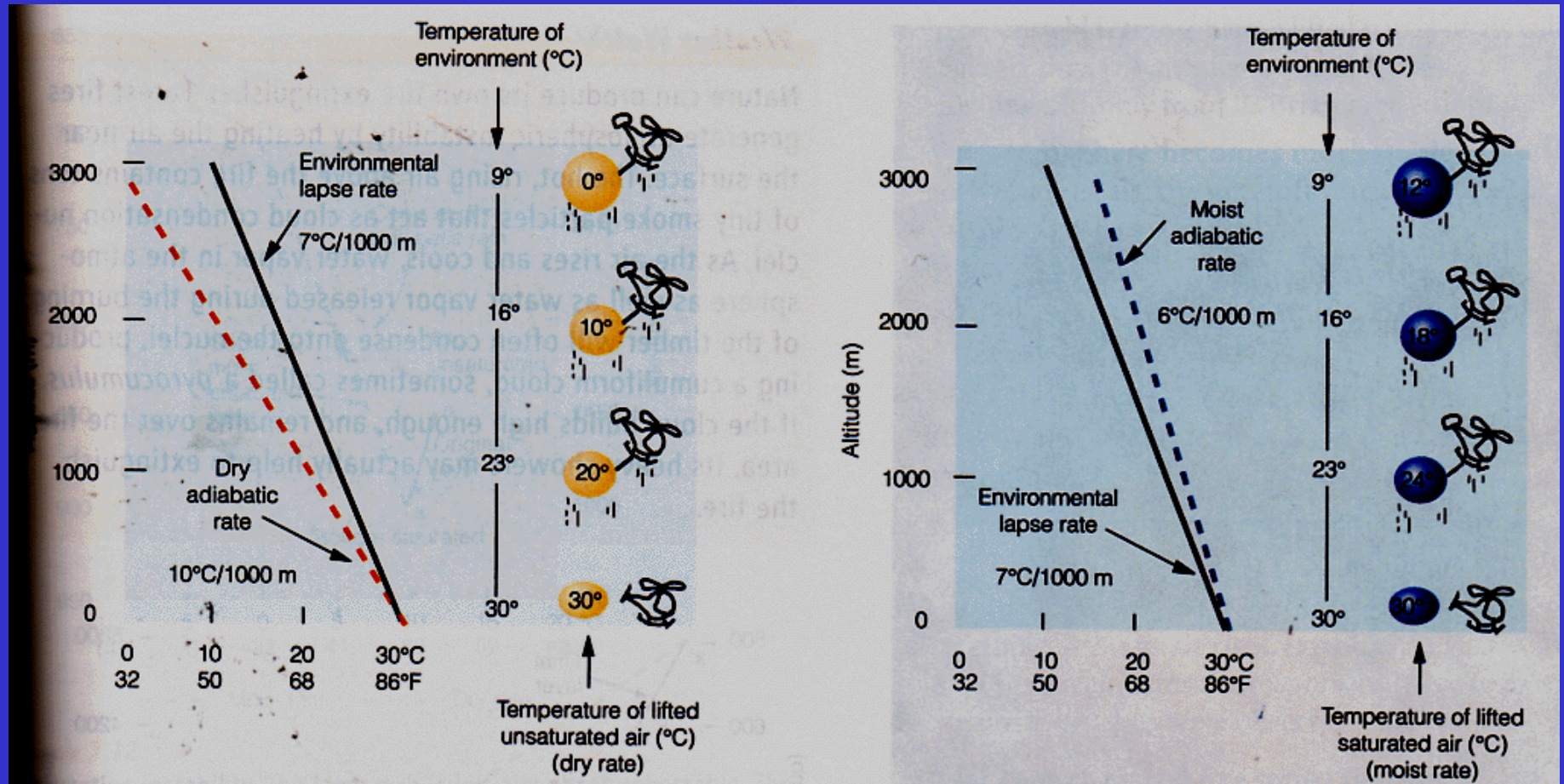

(from *Meteorology Today*)



# Day/Night Changes of Air Temperature

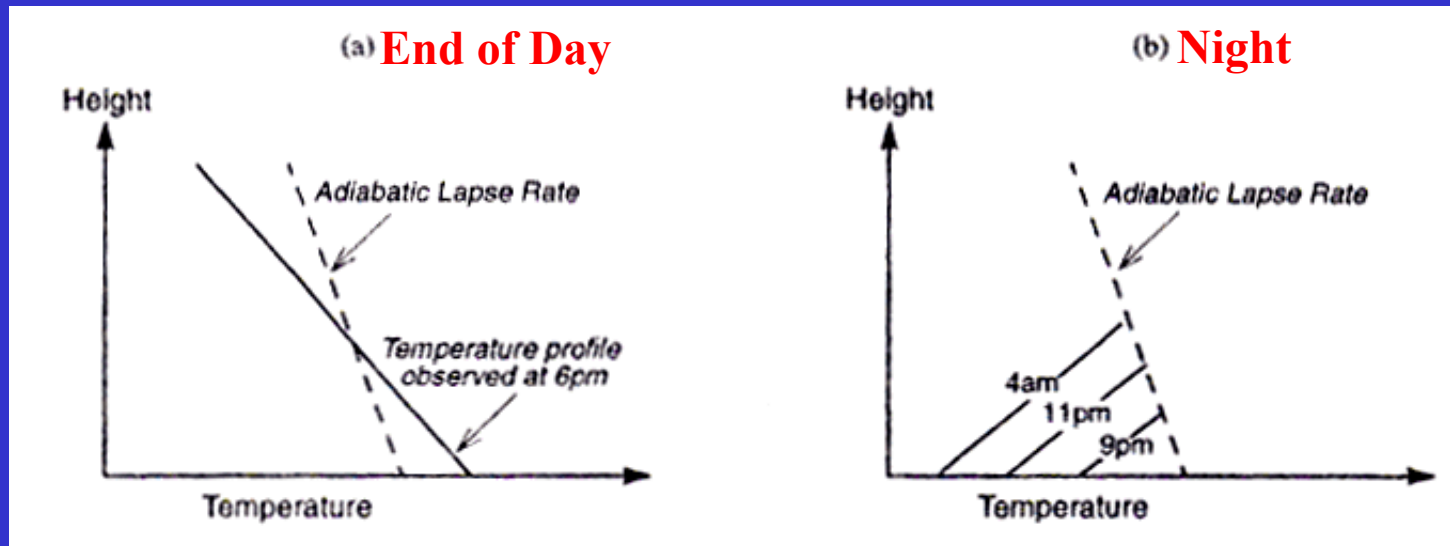

(from *Is the Temperature Rising?*)

- ❑ At the end of a sunny day, warm air near the surface, cold air aloft.
- ❑ In the early morning, cold air near the surface, warm air aloft.
- ❑ The later condition is called “inversion”, which inhibits convection and can cause severe pollution in the morning.



# Stability and Air Pollution

Neutral Atmosphere (Coning)

Stable Atmosphere (Fanning)

Unstable Atmosphere (Looping)

Stable Aloft; Unstable Below (Fumigation)

Unstable Aloft; Stable Below (Lofting)

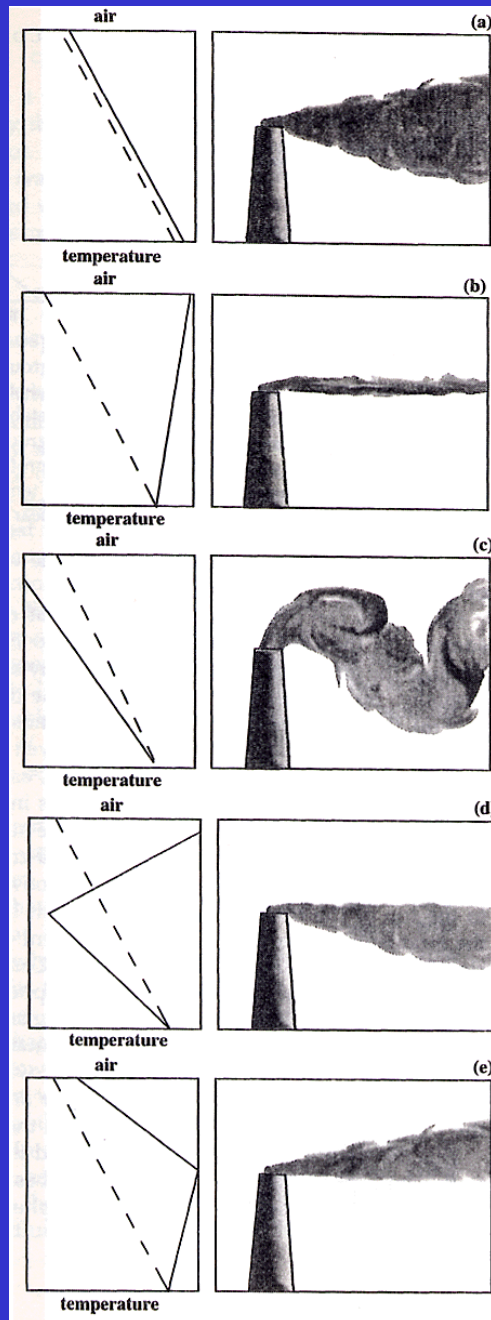

(from *Is the Temperature Rising?*)



ESS55  
Prof. Jin-Yi Yu

# Potential Temperature ( $\theta$ )

- The potential temperature of an air parcel is defined as the temperature the parcel would have if it were moved adiabatically from its existing pressure and temperature to a standard pressure  $P_0$  (generally taken as 1000mb).

$$\theta = T \left( \frac{P_0}{P} \right)^{\frac{R}{C_p}}$$

$\theta$  = potential temperature

$T$  = original temperature

$P$  = original pressure

$P_0$  = standard pressure = 1000 mb

$R$  = gas constant =  $R_d = 287 \text{ J deg}^{-1} \text{ kg}^{-1}$

$C_p$  = specific heat =  $1004 \text{ J deg}^{-1} \text{ kg}^{-1}$

$R/C_p = 0.286$



# Importance of Potential Temperature

- ❑ In the atmosphere, air parcel often moves around adiabatically. Therefore, its potential temperature remains constant throughout the whole process.
- ❑ Potential temperature is a conservative quantity for adiabatic process in the atmosphere.
- ❑ Potential temperature is an extremely useful parameter in atmospheric thermodynamics.



# Adiabatic Chart

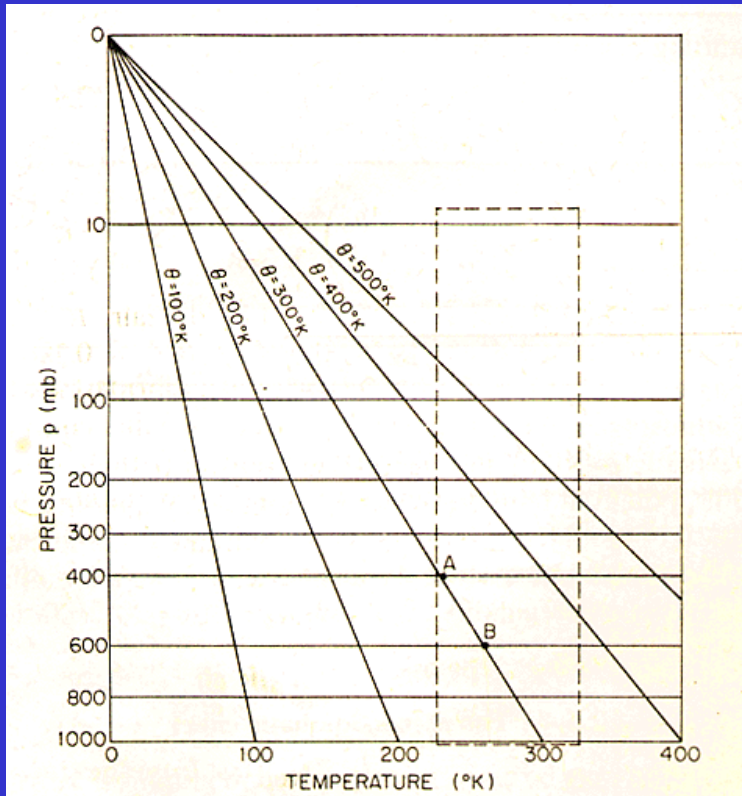

(from *Atmospheric Sciences: An Intro. Survey*)

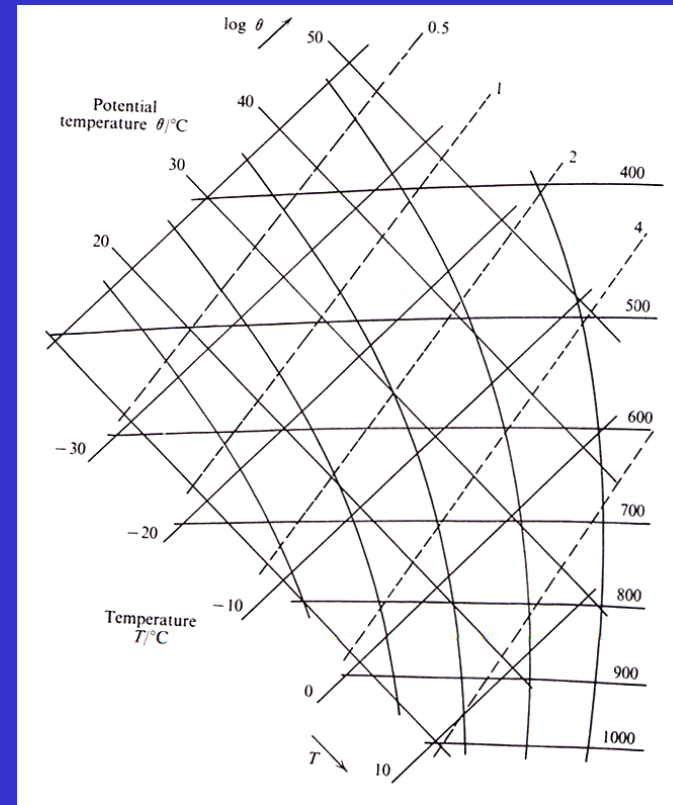

(from *The Physics of the Atmospheres*)

The expression of potential temperature can be modified into:

$$T = (\text{constant} * \theta) P^{0.286}$$



**red lines: dry adiabatic**

**blue dashed lines: moist adiabatic**

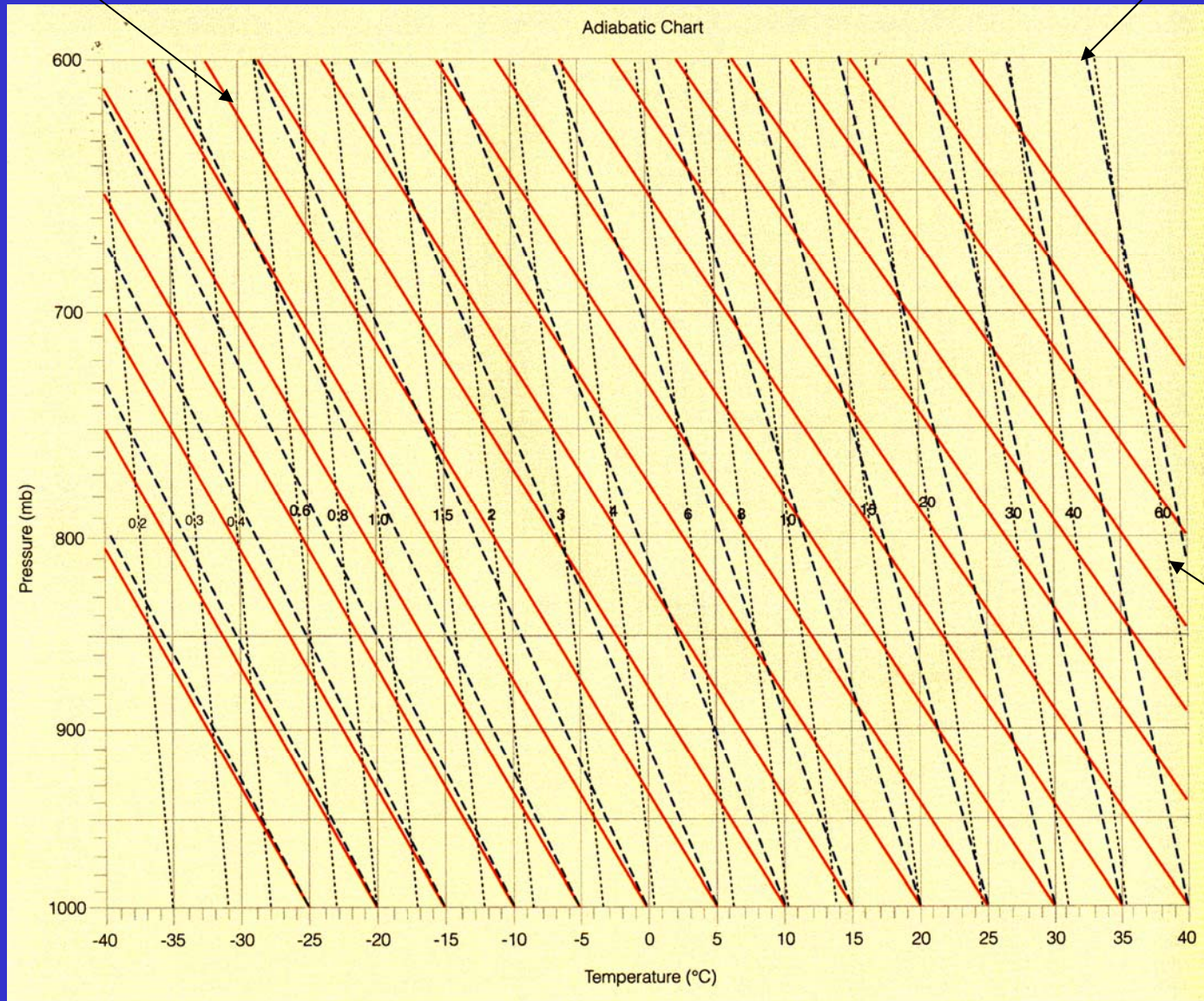

**gray lines:  
mixing ratio**

(from *Meteorology Today*)



ESS55  
Prof. Jin-Yi Yu

# Adiabatic Chart: $P$ and $T$

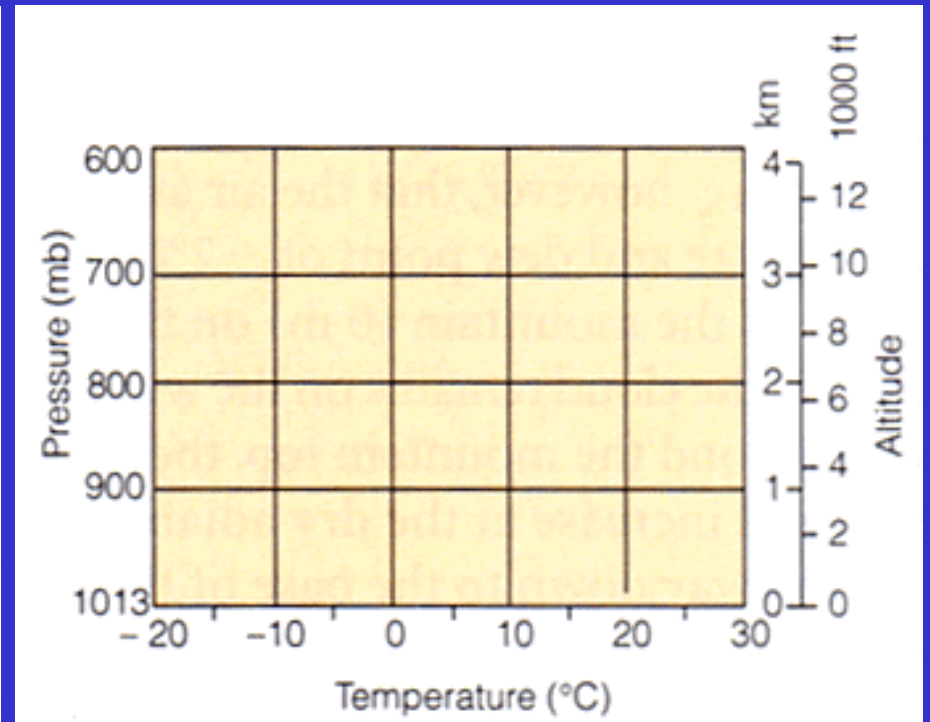
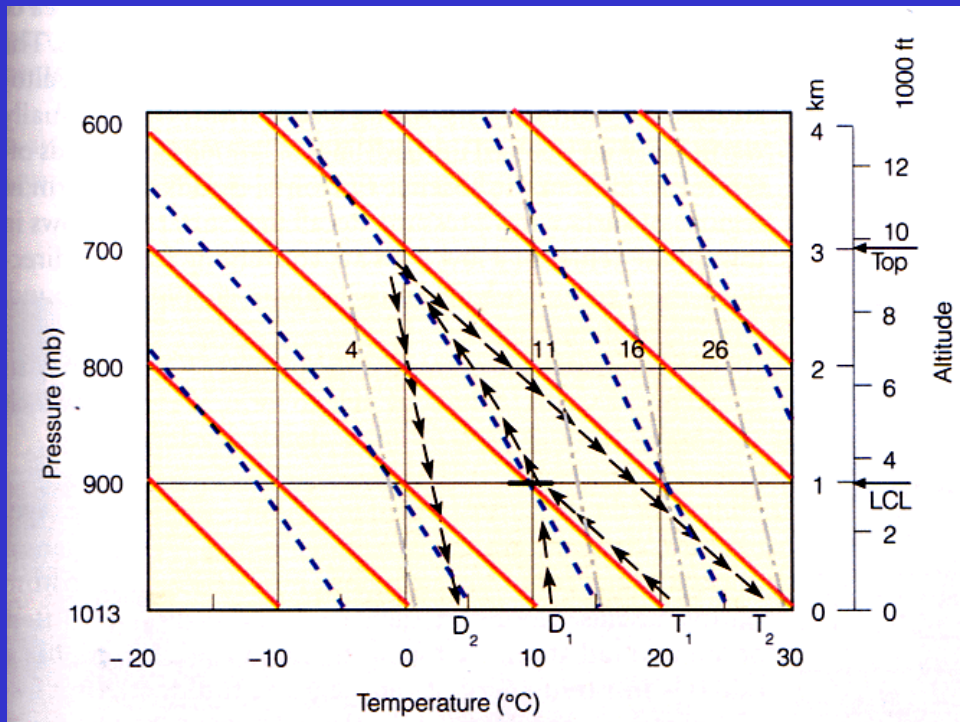

(from *Meteorology Today*)





# Adiabatic Chart: *Dry Adiabatic* / $\theta$

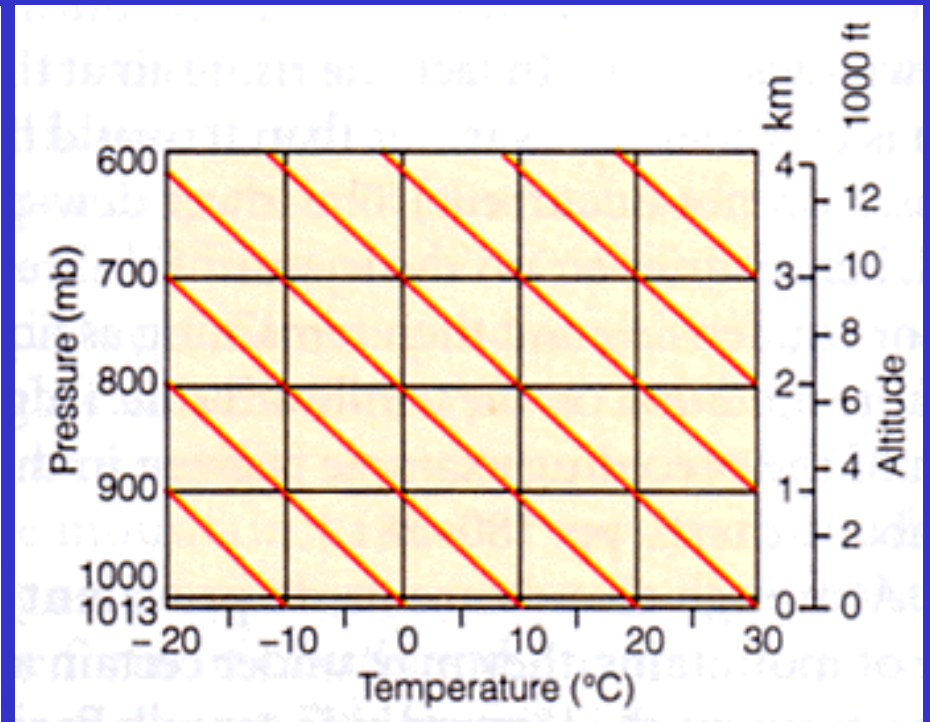
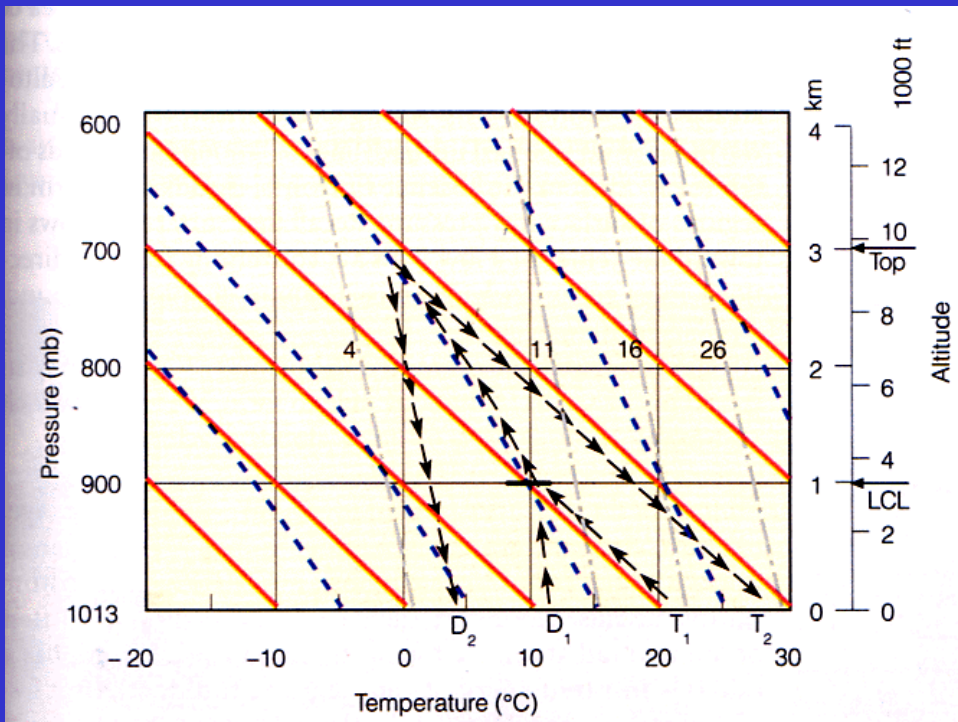

(from *Meteorology Today*)



# Adiabatic Chart: *Moist Adiabatic*

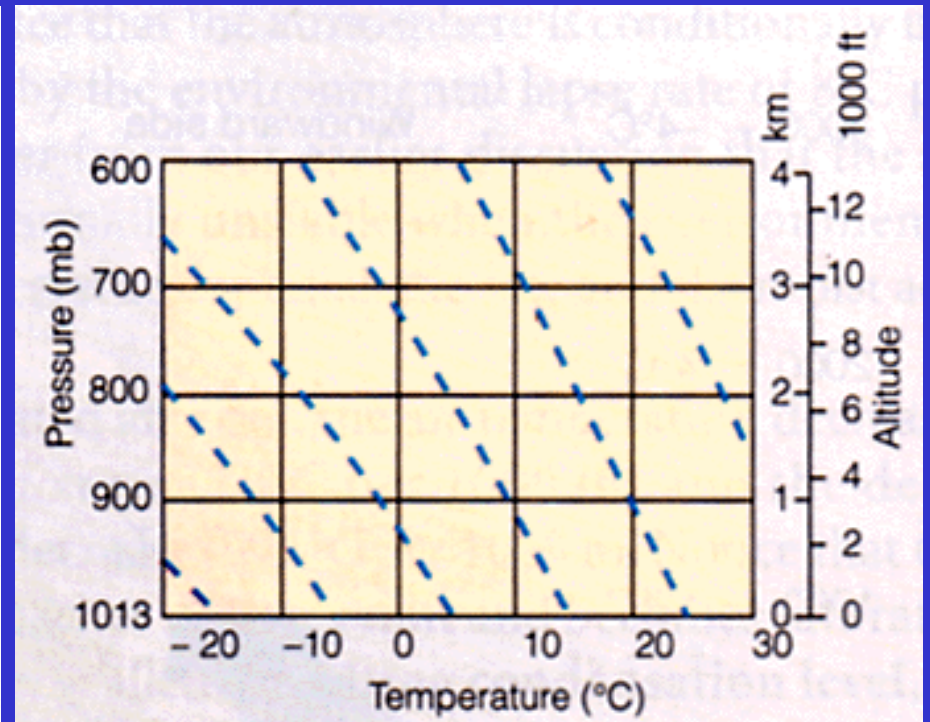
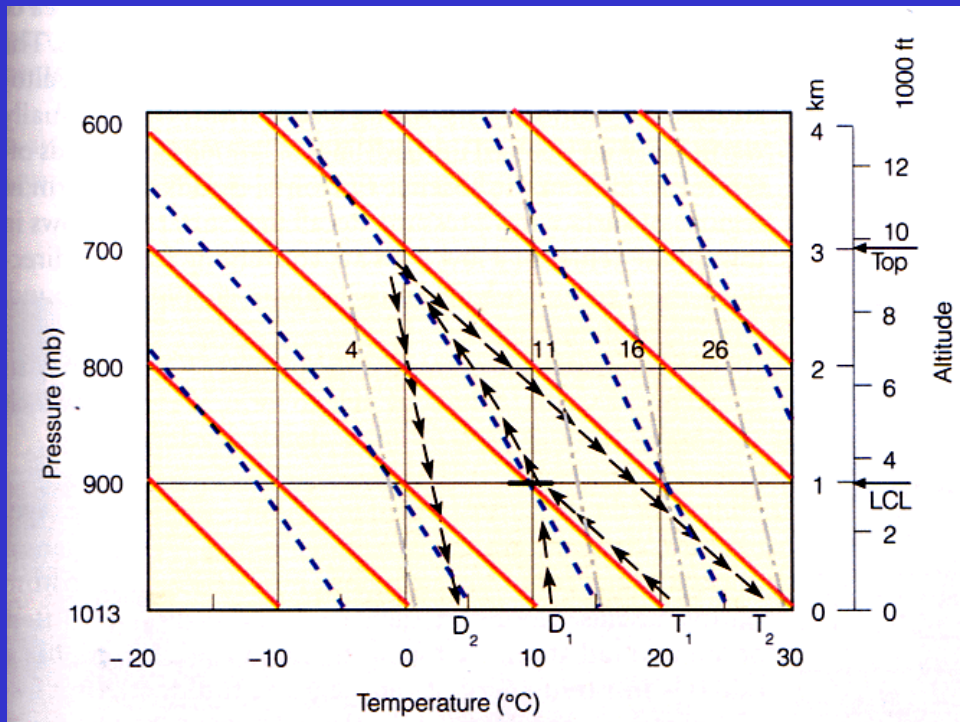

(from *Meteorology Today*)



# Adiabatic Chart: Saturated *Mixing Ratio* (g/kg)

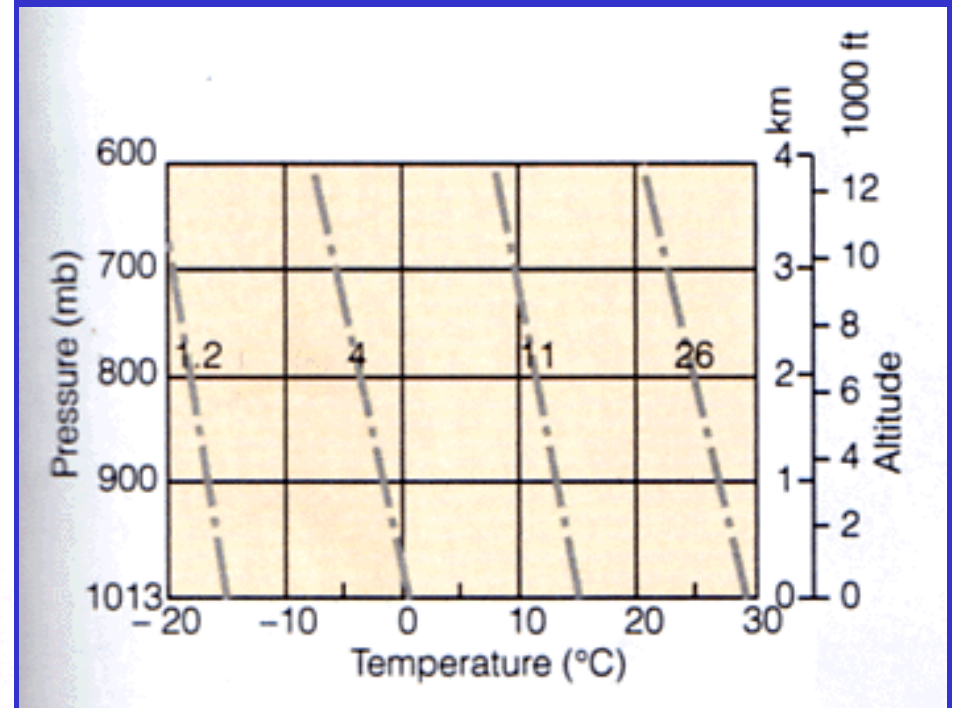
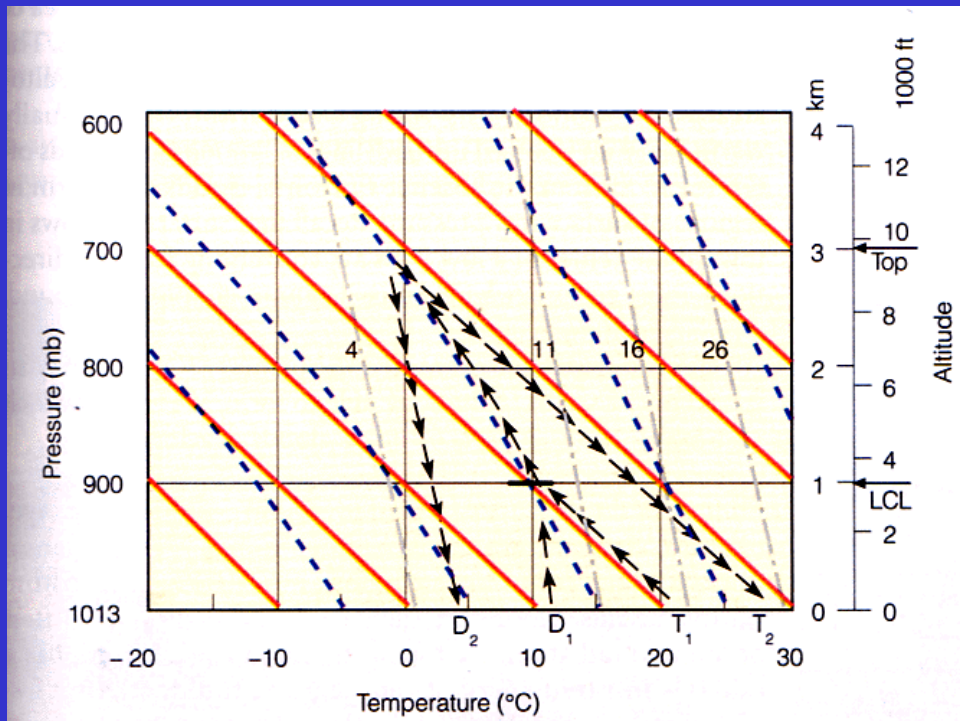

(from *Meteorology Today*)



# An Example

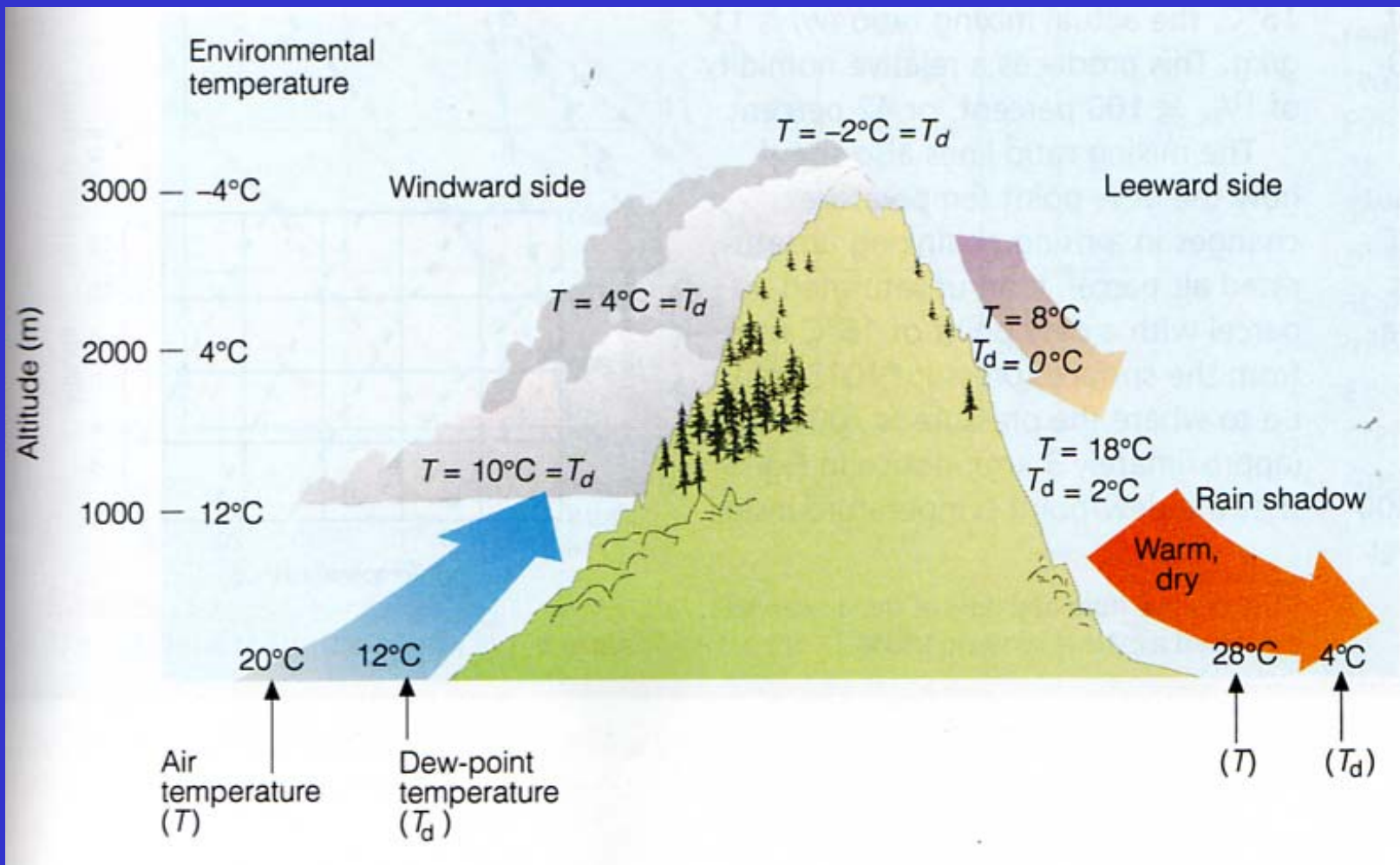

# Applications of Adiabatic Chart

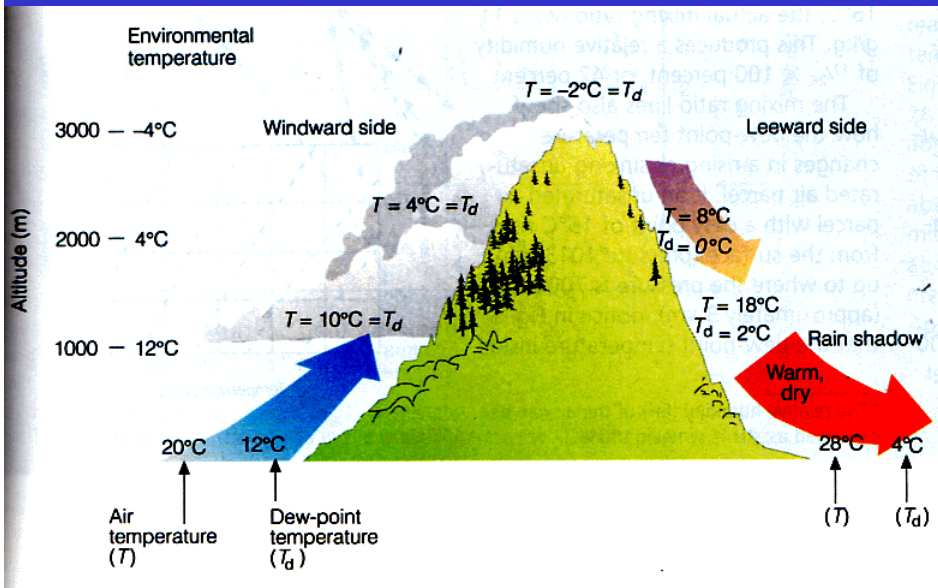

(from *Meteorology Today*)

