

# Lecture 4: Circulation and Vorticity

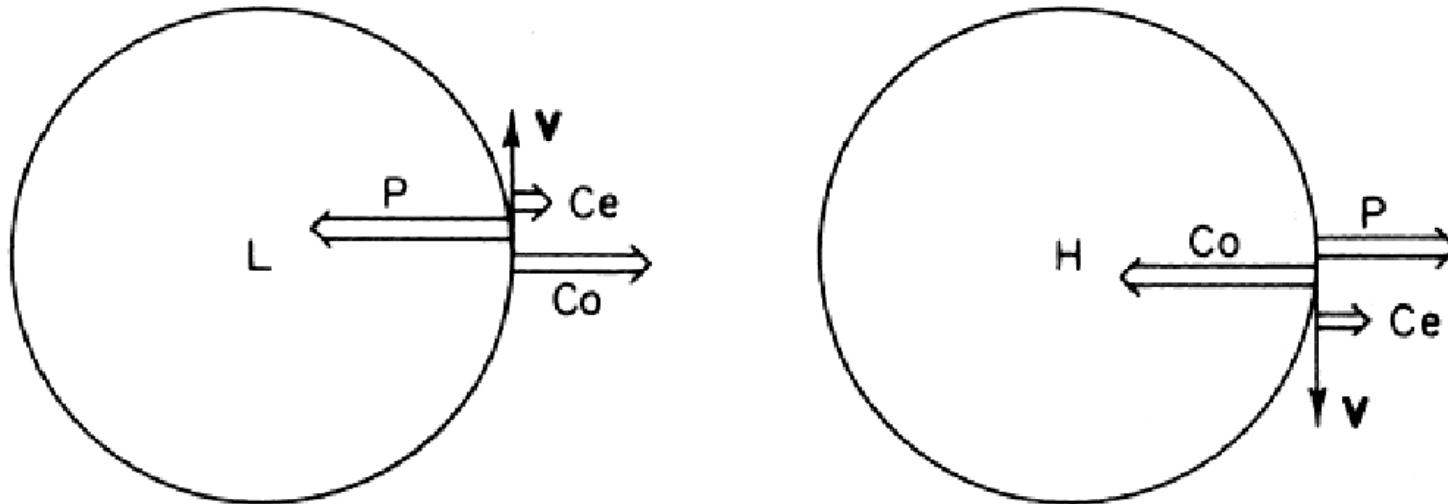

- Circulation
- Bjerknes Circulation Theorem
- Vorticity
- Potential Vorticity
- Conservation of Potential Vorticity



# Measurement of Rotation

- Circulation and vorticity are the two primary measures of rotation in a fluid.
- Circulation, which is a scalar integral quantity, is a *macroscopic* measure of rotation for a finite area of the fluid.
- Vorticity, however, is a vector field that gives a *microscopic* measure of the rotation at any point in the fluid.



# Circulation

- The *circulation*,  $C$ , about a closed contour in a fluid is defined as the line integral evaluated along the contour of the component of the velocity vector that is locally tangent to the contour.

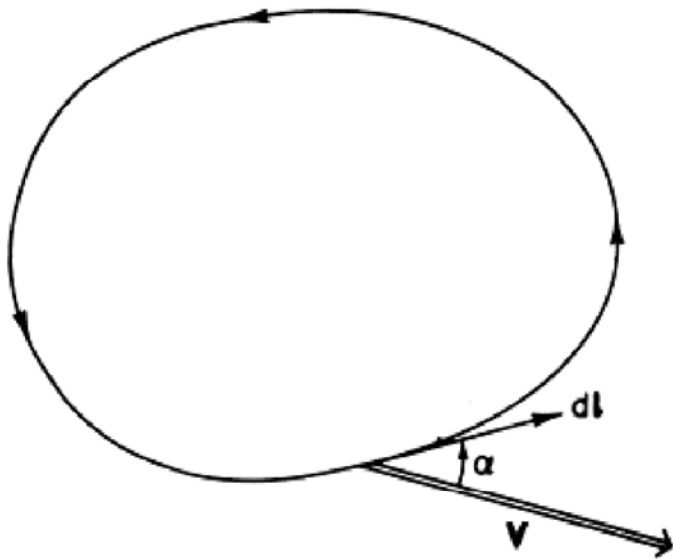

$$C \equiv \oint \mathbf{U} \cdot d\mathbf{l} = \oint |\mathbf{U}| \cos \alpha \, dl$$

$C > 0 \rightarrow$  Counterclockwise

$C < 0 \rightarrow$  Clockwise



# Example

- That circulation is a measure of rotation is demonstrated readily by considering a circular ring of fluid of radius  $R$  in solid-body rotation at angular velocity  $\Omega$  about the  $z$  axis.
- In this case,  $\mathbf{U} = \Omega \times \mathbf{R}$ , where  $\mathbf{R}$  is the distance from the axis of rotation to the ring of fluid. Thus the circulation about the ring is given by:

$$C \equiv \oint \mathbf{U} \cdot d\mathbf{l} = \int_0^{2\pi} \Omega R^2 d\lambda = 2\Omega\pi R^2$$

- In this case the circulation is just  $2\pi$  times the angular momentum of the fluid ring about the axis of rotation. Alternatively, note that  $C/(\pi R^2) = 2\Omega$  so that the circulation divided by the area enclosed by the loop is just twice the angular speed of rotation of the ring.
- Unlike angular momentum or angular velocity, circulation can be computed without reference to an axis of rotation; it can thus be used to characterize fluid rotation in situations where “angular velocity” is not defined easily.



# Solid Body Rotation

- In fluid mechanics, the state when no part of the fluid has motion relative to any other part of the fluid is called 'solid body rotation'.



# “Meaning” of Circulation

- Circulation can be considered as the amount of force that pushes along a closed boundary or path.
- Circulation is the total “push” you get when going along a path, such as a circle.



# Bjerknes Circulation Theorem

- The circulation theorem is obtained by taking the line integral of Newton's second law for a closed chain of fluid particles.

$$\int \left( \frac{DU}{Dt} = -2\boldsymbol{\Omega} \times \mathbf{U} - \frac{1}{\rho} \boldsymbol{\nabla} p + \mathbf{g} + \mathbf{F}_r \right) dl$$

becomes zero after integration neglect

$$\rightarrow \boxed{\frac{DC}{Dt} = - \oint \frac{dp}{\rho} - 2\boldsymbol{\Omega} \frac{DA_e}{Dt}}$$

**Term 1**

**Term 2**

**Term 3**

**Term 1:** rate of change of *relative* circulation

**Term 2:** solenoidal term (for a barotropic fluid, the density is a function only of pressure, and the solenoidal term is zero.)

**Term 3:** rate of change of the enclosed area projected on the equatorial plane



# Applications

## *Kelvin's circulation theorem*

- For a barotropic fluid, Bjerknes circulation theorem can be integrated following the motion from an initial state (designated by subscript 1) to a final state (designated by subscript 2), yielding the circulation change:

$$C_2 - C_1 = -2\Omega (A_2 \sin \phi_2 - A_1 \sin \phi_1)$$

This equation indicates that in a barotropic fluid the relative circulation for a closed chain of fluid particles will be changed if either the horizontal area enclosed by the loop changes or the latitude changes.

**Coriolis effect**

**divergence effect**

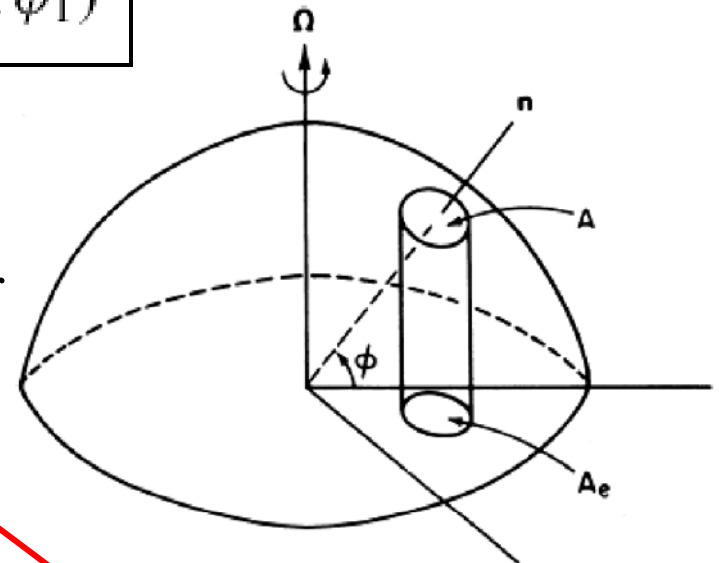



# Kelvin's Circulation Theorem

- In a barotropic fluid, the solenoid term (Term 2) vanishes.
- ➔ The absolute circulation ( $C_a$ ) is conserved following the parcel.



# Example

- Suppose that the air within a circular region of radius 100 km centered at the equator is *initially motionless* with respect to the earth. If this circular air mass were moved to the North Pole along an isobaric surface preserving its area, the circulation about the circumference would be:

$$C = -2\Omega\pi r^2[\sin(\pi/2) - \sin(0)]$$

- Thus the mean tangential velocity at the radius  $r = 100$  km would be:

$$V = C/(2\pi r) = -\Omega r \approx -7 \text{ m/sec}$$

- The negative sign here indicates that *the air has acquired anticyclonic relative circulation.*



# Solenoidal Term in Baroclinic Flow

- In a baroclinic fluid, circulation may be generated by the pressure-density solenoid term.
- This process can be illustrated effectively by considering the development of a sea breeze circulation,

$$\begin{aligned} \frac{DC_a}{Dt} &= - \oint \frac{dp}{\rho} \\ &= - \oint RT d \ln p \\ &= R \ln \left( \frac{p_0}{p_1} \right) (\bar{T}_2 - \bar{T}_1) > 0 \end{aligned}$$

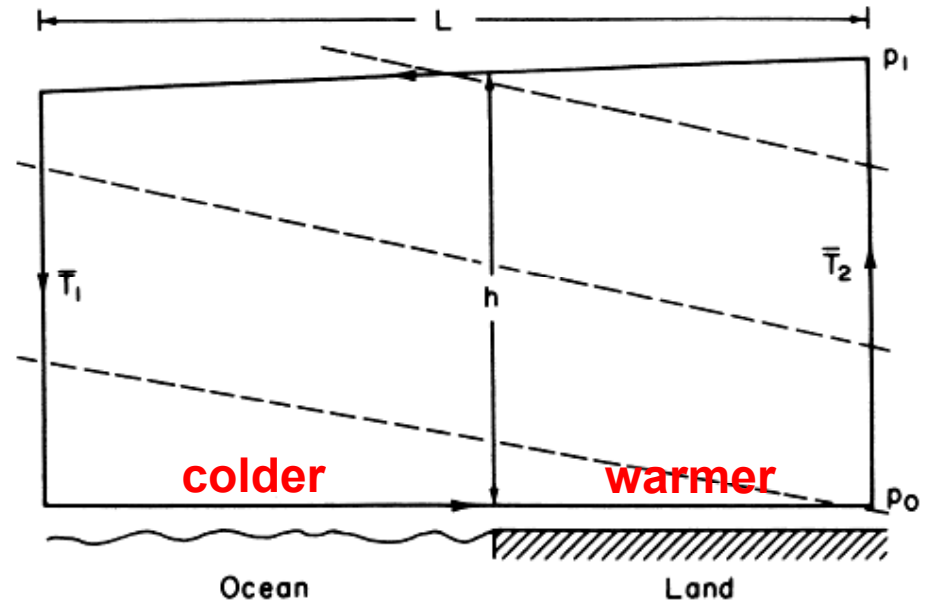

The closed heavy solid line is the loop about which the circulation is to be evaluated. Dashed lines indicate surfaces of constant density.

$$\frac{D\langle v \rangle}{Dt} = \frac{R \ln(p_0/p_1)}{2(h + L)} (\bar{T}_2 - \bar{T}_1)$$



# What does it mean?

- A counter-clockwise circulation (i.e., sea breeze) will develop in which lighter fluid (the warmer land air;  $T_2$ ) is made to rise and heavier fluid (the colder sea air;  $T_1$ ) is made to sink.
- The effect is this circulation will be to tilt the isopycnals into an orientation in which they are more nearly parallel with the isobars – that is, toward the barotropic state, in which subsequent circulation change would be zero.
- Such a circulation also lowers the center of mass of the fluid system and thus reduces the potential energy of that system.



# Strength of Sea-Breeze Circulation

$$\frac{D\langle v \rangle}{Dt} = \frac{R \ln(p_0/p_1)}{2(h + L)} (\bar{T}_2 - \bar{T}_1)$$

- Use the following value for the typical sea-land contrast:

$$p_0 = 1000 \text{ hPa}$$

$$p_1 = 900 \text{ hPa}$$

$$T_2 - T_1 = 10^\circ \text{ C}$$

$$L = 20 \text{ km}$$

$$h = 1 \text{ km}$$

- We obtain an acceleration of about  $7 \times 10^{-3} \text{ ms}^{-2}$  for an acceleration of sea-breeze circulation driven by the solenoidal effect of sea-land temperature contrast.



# Vorticity

- Vorticity is the tendency for elements of the fluid to "spin."
- Vorticity can be related to the amount of "circulation" or "rotation" (or more strictly, the local angular rate of rotation) in a fluid.
- Definition:

Absolute Vorticity  $\rightarrow \boldsymbol{\omega}_a \equiv \nabla \times \mathbf{U}_a$

Relative Vorticity  $\rightarrow \boldsymbol{\omega} \equiv \nabla \times \mathbf{U}$

$$\boldsymbol{\omega} = \left( \frac{\partial w}{\partial y} - \frac{\partial v}{\partial z}, \frac{\partial u}{\partial z} - \frac{\partial w}{\partial x}, \frac{\partial v}{\partial x} - \frac{\partial u}{\partial y} \right)$$



# Vertical Component of Vorticity

- In large-scale dynamic meteorology, we are in general concerned only with the vertical components of absolute and relative vorticity, which are designated by  $\eta$  and  $\zeta$ , respectively.

$$\eta \equiv \mathbf{k} \cdot (\nabla \times \mathbf{U}_a), \quad \zeta \equiv \mathbf{k} \cdot (\nabla \times \mathbf{U})$$

$$\eta = \frac{\partial v}{\partial x} - \frac{\partial u}{\partial y} + f$$

$$\zeta = \frac{\partial v}{\partial x} - \frac{\partial u}{\partial y}$$



# Vorticity and Circulation

$$\zeta \equiv \lim_{A \rightarrow 0} \left( \oint \mathbf{V} \cdot d\mathbf{l} \right) A^{-1}$$

The vertical component of vorticity is defined as the circulation about a closed contour in the horizontal plane divided by the area enclosed, in the limit where the area approaches zero.

$$\begin{aligned} \delta C &= u\delta x + \left( v + \frac{\partial v}{\partial x} \delta x \right) \delta y - \left( u + \frac{\partial u}{\partial y} \delta y \right) \delta x - v\delta y \\ &= \left( \frac{\partial v}{\partial x} - \frac{\partial u}{\partial y} \right) \delta x \delta y \end{aligned}$$

Dividing through by the area  $\delta A = \delta x \delta y$  gives

$$\frac{\delta C}{\delta A} = \left( \frac{\partial v}{\partial x} - \frac{\partial u}{\partial y} \right) \equiv \zeta$$

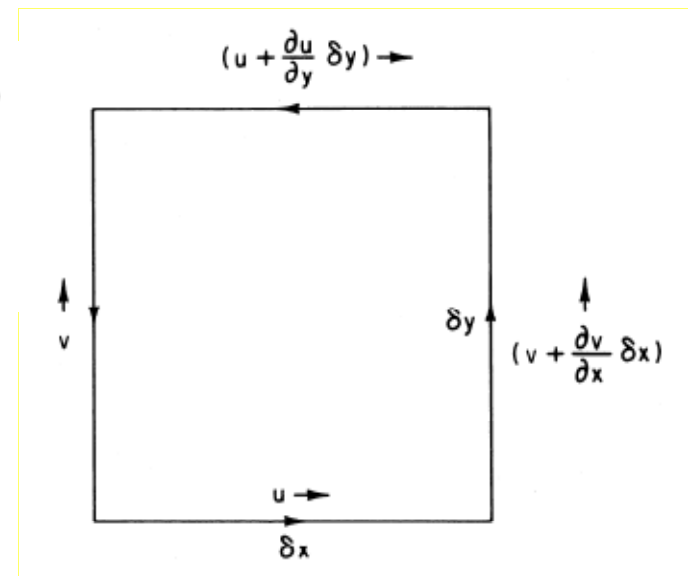



# Stoke's Theorem

$$\oint \mathbf{U} \cdot d\mathbf{l} = \iint_A (\nabla \times \mathbf{U}) \cdot \mathbf{n} dA$$

- Stokes' theorem states that the circulation about any closed loop is equal to the integral of the normal component of vorticity over the area enclosed by the contour.
- For a finite area, circulation divided by area gives the *average* normal component of vorticity in the region.
- Vorticity may thus be regarded as a measure of the local angular velocity of the fluid.



# Vorticity in Natural Coordinate

- Vorticity can be associated with only two broad types of flow configuration.
- It is easier to demonstrate this by considering the vertical component of vorticity in natural coordinates.

$$\delta C = V[\delta s + d(\delta s)] - \left( V + \frac{\partial V}{\partial n} \delta n \right) \delta s$$

$$d(\delta s) = \delta \beta \delta n$$

$$\delta C = \left( -\frac{\partial V}{\partial n} + V \frac{\delta \beta}{\delta s} \right) \delta n \delta s$$

$$\zeta = \lim_{\delta n, \delta s \rightarrow 0} \frac{\delta C}{(\delta n \delta s)} = -\frac{\partial V}{\partial n} + \frac{V}{R_s}$$

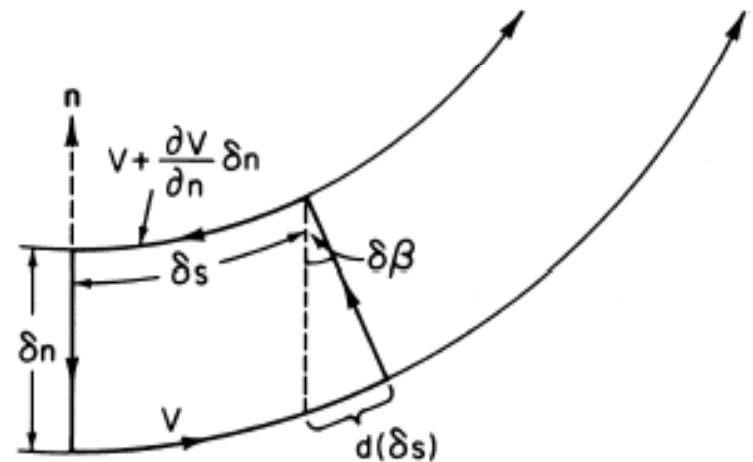

shear vorticity

curvature vorticity



# Vorticity-Related Flow Patterns

## Shear Vorticity

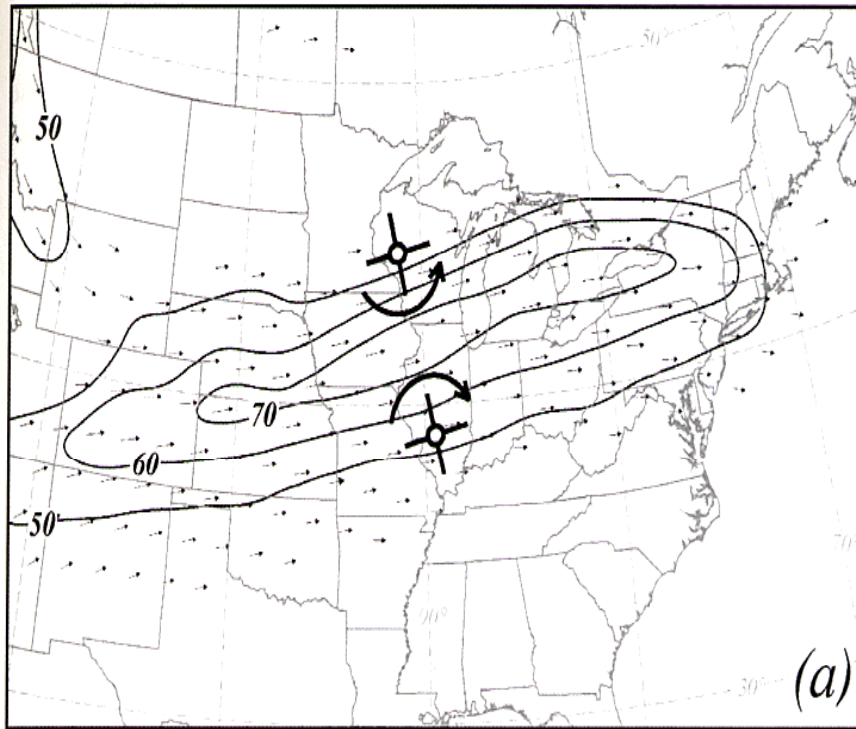

## Vorticity Vorticity

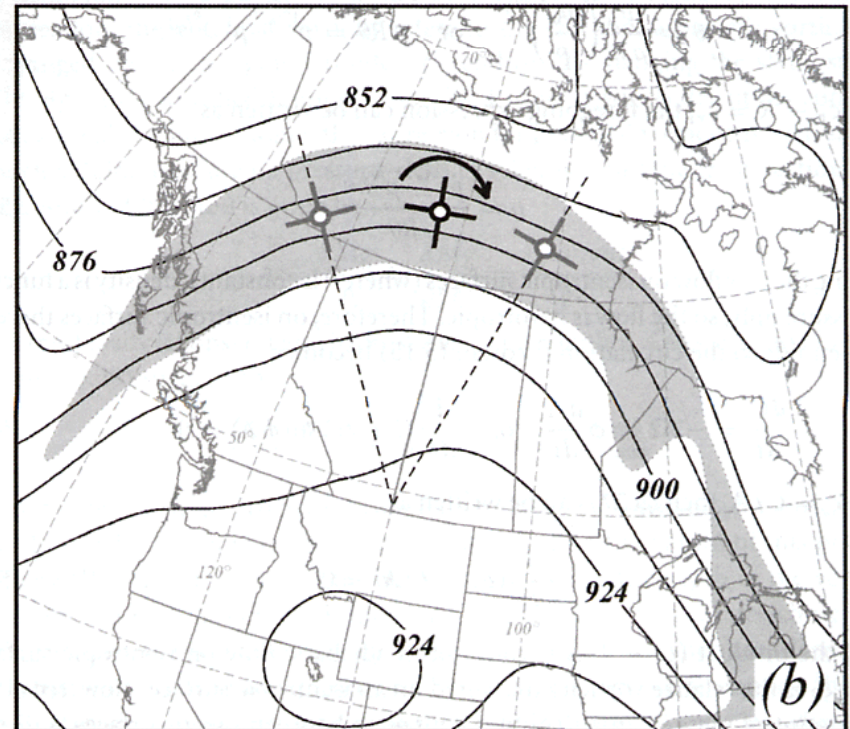

Even straight-line motion may have vorticity if the speed changes normal to the flow axis.

**(a) 300mb isotachs; (b) 300mb geopotential heights**



# Potential Vorticity

- We begin with the “circulation equation” (Bjerknes circulation theorem)

$$\frac{DC}{Dt} = - \oint \frac{dp}{\rho} - 2\Omega \frac{DA_e}{Dt} \quad (\text{where } A_e = A \sin\Phi)$$

- We then make use of definitions of potential temperature ( $\Theta$ ) and vorticity ( $\zeta$ )

$$\theta = T (p_s/p)^{R/c_p} \rightarrow \rho = p^{c_v/c_p} (R\theta)^{-1} (p_s)^{R/c_p}$$

$$\rightarrow \oint \frac{dp}{\rho} \propto \oint dp^{(1-c_v/c_p)} = 0$$

$$C \approx \zeta \delta A$$

- We then make use of definitions of potential temperature ( $\Theta$ ) and vorticity ( $\zeta$ )

$$\delta A(\zeta_\theta + f) = \text{Const} \quad (\text{where } f = 2\Omega \sin\phi)$$

$$\delta A = -\frac{\delta Mg}{\delta p} = \left(-\frac{\delta\theta}{\delta p}\right) \left(\frac{\delta Mg}{\delta\theta}\right) = \text{Const} \times g \left(-\frac{\delta\theta}{\delta p}\right)$$

$$P \equiv (\zeta_\theta + f) \left(-g \frac{\partial\theta}{\partial p}\right) = \text{Const}$$



# *Ertel's Potential Vorticity*

$$P \equiv (\zeta_{\theta} + f) \left( -g \frac{\partial \theta}{\partial p} \right)$$

- The quantity  $P$  [units:  $\text{K kg}^{-1} \text{m}^2 \text{s}^{-1}$ ] is the isentropic coordinate form of *Ertel's potential vorticity*.
- *It is defined with a minus sign so that its value is normally positive in the Northern Hemisphere.*
- Potential vorticity is often expressed in the potential vorticity unit (PVU), where  $1 \text{ PVU} = 10^{-6} \text{ K kg}^{-1} \text{m}^2 \text{s}^{-1}$ .
- Potential vorticity is always in some sense a measure of the ratio of the absolute vorticity to the *effective depth of the vortex*.
- The effective depth is just the differential distance between potential temperature surfaces measured in pressure units ( $-\partial\theta/\partial p$ ).



# “Depth” of Potential Vorticity

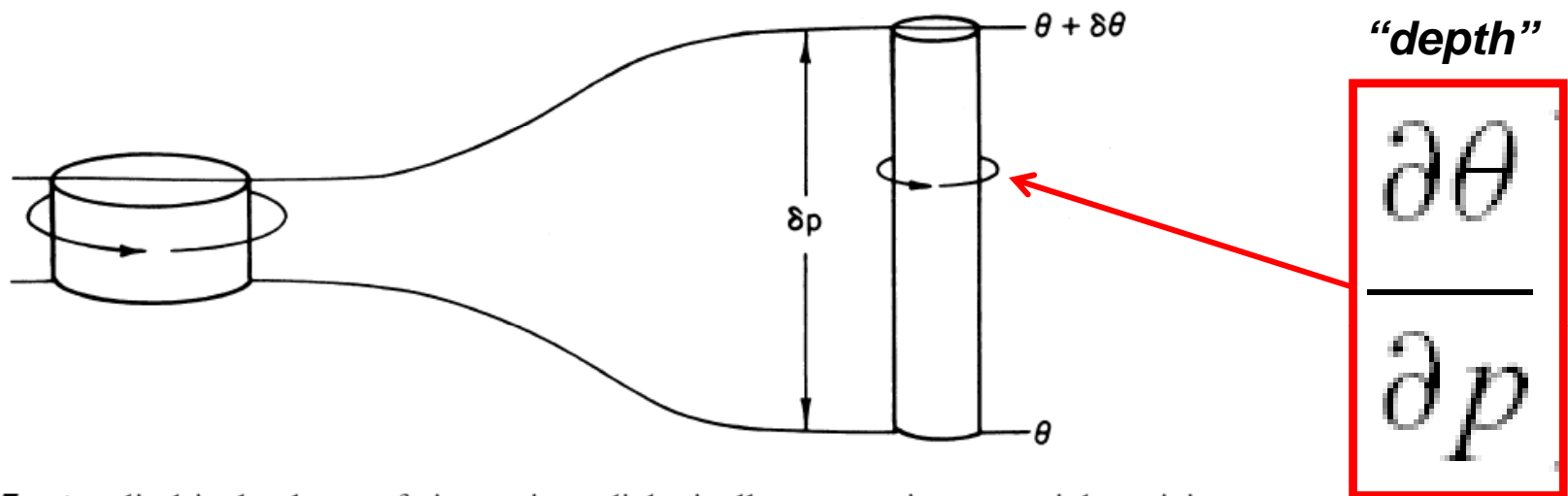

Fig. 4.7 A cylindrical column of air moving adiabatically, conserving potential vorticity.

- In a homogeneous incompressible fluid, potential vorticity conservation takes a somewhat simpler form

Using  $\delta A = M(\rho h)^{-1} = \text{Const}/h$

$$(\zeta + f)/h = \eta/h = \text{Const}$$

**Rossby Potential  
Vorticity Conservation  
Law**



# Flows Cross Over a Mountain

## Westerly over mountain

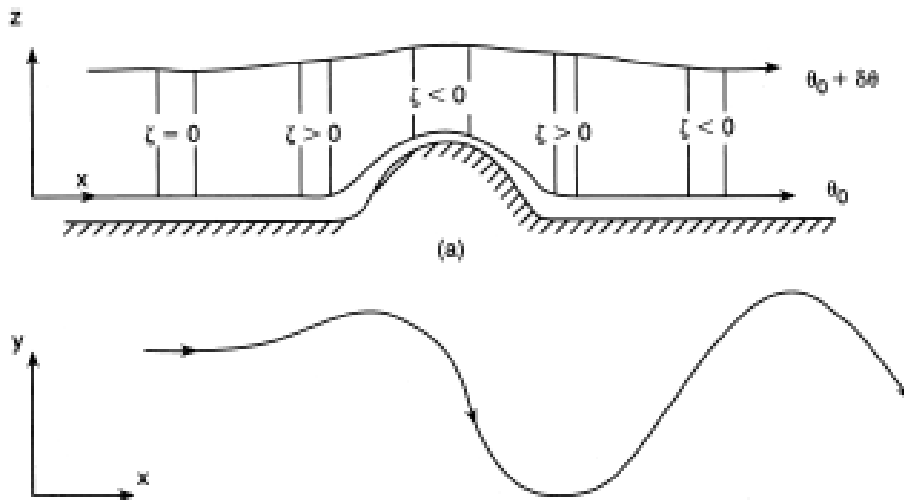

Steady westerly flow over a large-scale ridge will result in a cyclonic flow pattern immediately to the east of the barrier (the lee side trough) followed by an alternating series of ridges and troughs downstream.

## Easterly over mountain

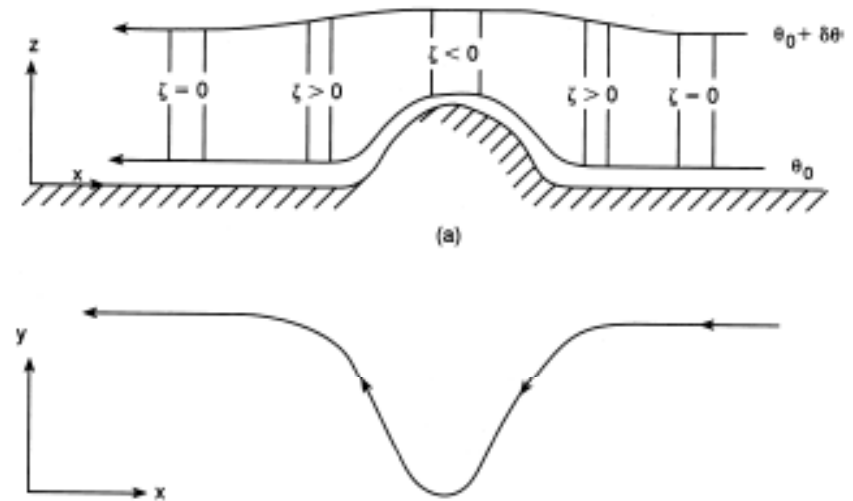

In the case of an easterly wind, the disturbance in the streamlines damps out away from the barrier.



# Depth and Latitude

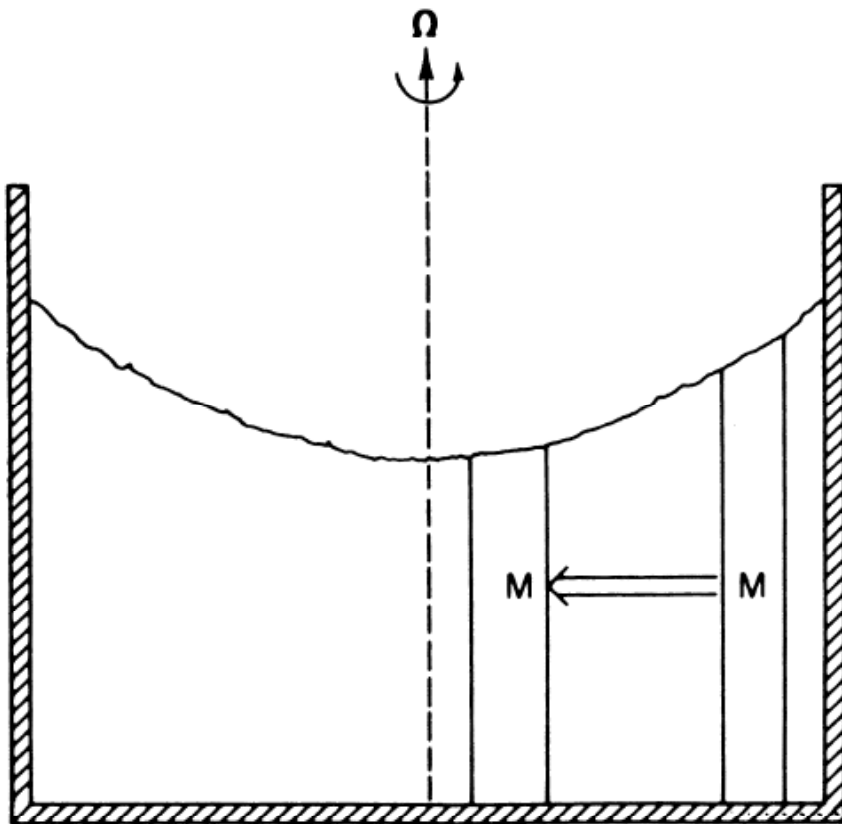

- The Rossby potential vorticity conservation law indicates that in a barotropic fluid, a change in the depth is dynamically analogous to a change in the Coriolis parameter.
- Therefore, in a barotropic fluid, a decrease of depth with increasing latitude has the same effect on the relative vorticity as the increase of the Coriolis force with latitude.





# Vorticity Equation

(1) Begins with the Eq of motion:

$$\frac{\partial}{\partial y} \left( \frac{\partial u}{\partial t} + u \frac{\partial u}{\partial x} + v \frac{\partial u}{\partial y} + w \frac{\partial u}{\partial z} - fv \right) = -\frac{1}{\rho} \frac{\partial p}{\partial x}$$

$$\frac{\partial}{\partial x} \left( \frac{\partial v}{\partial t} + u \frac{\partial v}{\partial x} + v \frac{\partial v}{\partial y} + w \frac{\partial v}{\partial z} + fu \right) = -\frac{1}{\rho} \frac{\partial p}{\partial y}$$

(2) Use the definition of relative vorticity ( $\zeta$ ):

$$\begin{aligned} \frac{\partial \zeta}{\partial t} + u \frac{\partial \zeta}{\partial x} + v \frac{\partial \zeta}{\partial y} + w \frac{\partial \zeta}{\partial z} + (\zeta + f) \left( \frac{\partial u}{\partial x} + \frac{\partial v}{\partial y} \right) = \\ + \left( \frac{\partial w}{\partial x} \frac{\partial v}{\partial z} - \frac{\partial w}{\partial y} \frac{\partial u}{\partial z} \right) + v \frac{df}{dy} = \frac{1}{\rho^2} \left( \frac{\partial \rho}{\partial x} \frac{\partial p}{\partial y} - \frac{\partial \rho}{\partial y} \frac{\partial p}{\partial x} \right) \end{aligned}$$

(3) We get the vorticity equation:

$$\begin{aligned} \frac{D}{Dt} (\zeta + f) = - (\zeta + f) \left( \frac{\partial u}{\partial x} + \frac{\partial v}{\partial y} \right) \\ - \left( \frac{\partial w}{\partial x} \frac{\partial v}{\partial z} - \frac{\partial w}{\partial y} \frac{\partial u}{\partial z} \right) + \frac{1}{\rho^2} \left( \frac{\partial \rho}{\partial x} \frac{\partial p}{\partial y} - \frac{\partial \rho}{\partial y} \frac{\partial p}{\partial x} \right) \end{aligned}$$

*(1) divergence term*

*(2) tilting term*

*(3) solenoid term*



# Divergence Term

- If the horizontal flow is divergent, the area enclosed by a chain of fluid parcels will increase with time and if circulation is to be conserved, the average absolute vorticity of the enclosed fluid must decrease (i.e., the vorticity will be diluted).
- If, however, the flow is convergent, the area enclosed by a chain of fluid parcels will decrease with time and the vorticity will be concentrated.
- This mechanism for changing vorticity following the motion is very important in synoptic-scale disturbances.



# Tilting (or Twisting) Term

- Convert vorticity in X and Y directions into the Z-direction by the tilting/twisting effect produced by the vertical velocity ( $\partial w/\partial x$  and  $\partial w/\partial y$ ).

$$-\left( \frac{\partial w}{\partial x} \frac{\partial v}{\partial z} - \frac{\partial w}{\partial y} \frac{\partial u}{\partial z} \right)$$

$\frac{\partial u}{\partial z} \rightarrow$  vorticity in Y-direction

$\frac{\partial w}{\partial y} \rightarrow$  Tilting by the variation of w in Y-direction

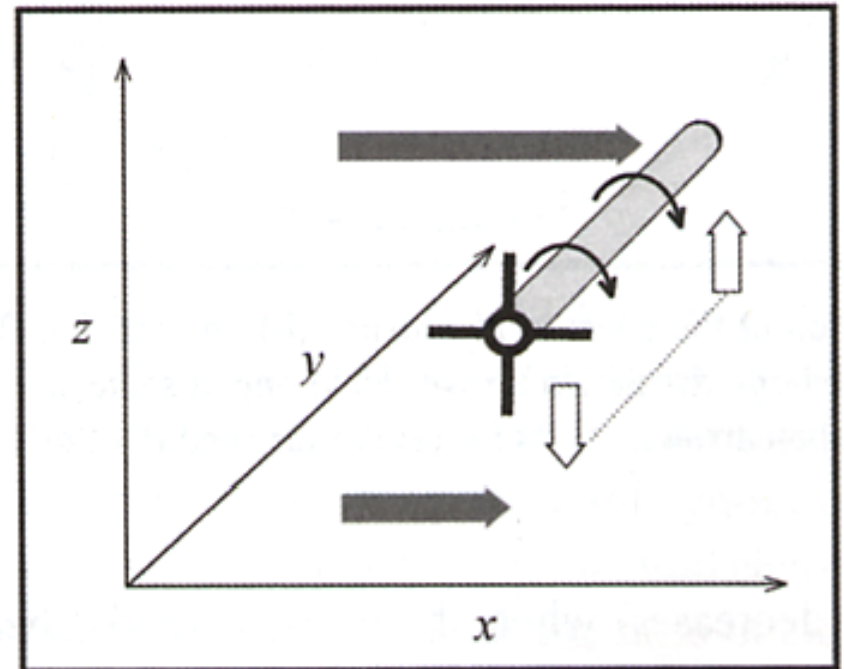

# Solenoid Term

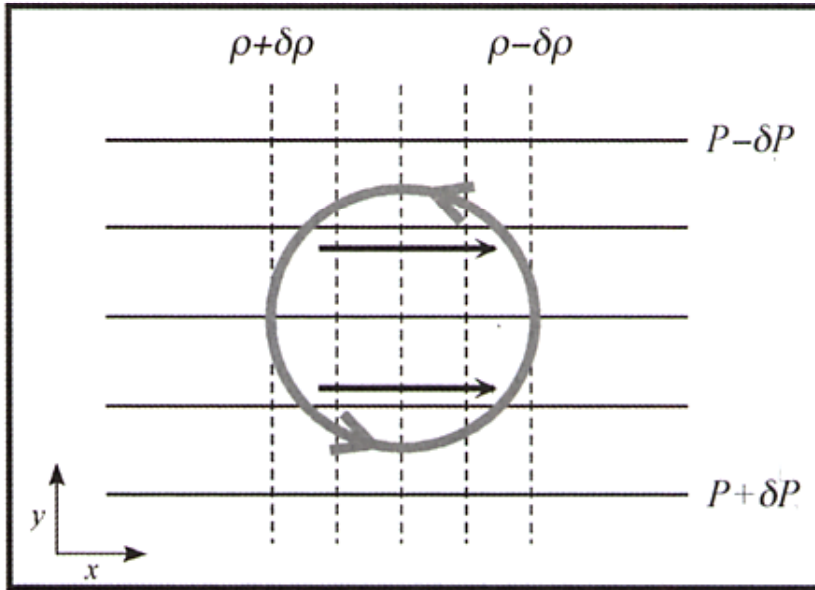

$$\frac{1}{\rho^2} \left( \frac{\partial \rho}{\partial x} \frac{\partial p}{\partial y} - \frac{\partial \rho}{\partial y} \frac{\partial p}{\partial x} \right)$$

- Given appropriate horizontal configurations of  $p$  and  $\rho$ , vorticity can be produced.
- In this example, cyclonic vorticity will rotate the isopycnals until they are parallel with the isobars in a configuration in which high pressure corresponds to high density and vice versa.



# Scale Analysis of Vorticity Equation

$$\frac{D}{Dt}(\zeta + f) = -(\zeta + f) \left( \frac{\partial u}{\partial x} + \frac{\partial v}{\partial y} \right) - \left( \frac{\partial w}{\partial x} \frac{\partial v}{\partial z} - \frac{\partial w}{\partial y} \frac{\partial u}{\partial z} \right) + \frac{1}{\rho^2} \left( \frac{\partial \rho}{\partial x} \frac{\partial p}{\partial y} - \frac{\partial \rho}{\partial y} \frac{\partial p}{\partial x} \right)$$

**Scaled for mid-latitude synoptic-scale weather**

$U \sim 10 \text{ m s}^{-1}$	horizontal scale
$W \sim 1 \text{ cm s}^{-1}$	vertical scale
$L \sim 10^6 \text{ m}$	length scale
$H \sim 10^4 \text{ m}$	depth scale
$\delta p \sim 10 \text{ hPa}$	horizontal pressure scale
$\rho \sim 1 \text{ kg m}^{-3}$	mean density
$\delta \rho / \rho \sim 10^{-2}$	fractional density fluctuation
$L/U \sim 10^5 \text{ s}$	time scale
$f_0 \sim 10^{-4} \text{ s}^{-1}$	Coriolis parameter
$\beta \sim 10^{-11} \text{ m}^{-1} \text{ s}^{-1}$	“beta” parameter

$$\frac{D_h(\zeta + f)}{Dt} = -f \left( \frac{\partial u}{\partial x} + \frac{\partial v}{\partial y} \right)$$

$$\frac{D_h}{Dt} \equiv \frac{\partial}{\partial t} + u \frac{\partial}{\partial x} + v \frac{\partial}{\partial y}$$



# But for Intense Cyclonic Storms..

$$\frac{D_h (\zeta + f)}{Dt} = - (\zeta + f) \left( \frac{\partial u}{\partial x} + \frac{\partial v}{\partial y} \right)$$

- In intense cyclonic storms, the relative vorticity should be retained in the divergence term.



# For a Barotropic Flow

$$(1) \frac{D_h (\zeta + f)}{Dt} = - (\zeta + f) \left( \frac{\partial u}{\partial x} + \frac{\partial v}{\partial y} \right)$$

$$\rightarrow \frac{D_h (\zeta + f)}{Dt} = (\zeta + f) \left( \frac{\partial w}{\partial z} \right)$$

$$h \frac{D_h (\zeta_g + f)}{Dt} = (\zeta_g + f) [w(z_2) - w(z_1)] = \frac{Dz_2}{Dt} - \frac{Dz_1}{Dt} = \frac{D_h h}{Dt}$$

$$\rightarrow \frac{1}{(\zeta_g + f)} \frac{D_h (\zeta_g + f)}{Dt} = \frac{1}{h} \frac{D_h h}{Dt}$$

$$\rightarrow \frac{D_h \ln (\zeta_g + f)}{Dt} = \frac{D_h \ln h}{Dt}$$

**Rossby Potential Vorticity**

$$\rightarrow \frac{D_h}{Dt} \left( \frac{\zeta_g + f}{h} \right) = 0$$



# Stream Function

- For horizontal motion that is non-divergent ( $\partial u/\partial x + \partial v/\partial y = 0$ ), the flow field can be represented by a *streamfunction*  $\psi(x, y)$  defined so that the velocity components are given as

$$u = -\partial\psi/\partial y,$$

$$v = +\partial\psi/\partial x.$$

- The vorticity is then given by

$$\zeta = \partial v/\partial x - \partial u/\partial y = \partial^2\psi/\partial x^2 + \partial^2\psi/\partial y^2 \equiv \nabla^2\psi$$





# Velocity Potential

A **velocity potential** is used in fluid dynamics, when a fluid occupies a simply-connected region and is irrotational. In such a case,

$$\nabla \times \mathbf{u} = 0,$$

where  $\mathbf{u}$  denotes the flow velocity of the fluid. As a result,  $\mathbf{u}$  can be represented as the gradient of a scalar function  $\Phi$ :

$$\mathbf{u} = \nabla \Phi,$$

$\Phi$  is known as a **velocity potential** for  $\mathbf{u}$ .

