

Radiocarbon – a low-impact tool to study nutrient transport by soil fungi under field conditions

Claudia I. Czimczik¹, Kathleen K. Treseder^{1,2}, Mariah S. Carbone¹ and Susan E. Trumbore¹

¹Department of Earth System Science, 2103 Croul Hall, University of California, Irvine, CA 92697–3100, USA; ²Department of Ecology and Evolutionary Biology, University of California, Irvine, CA 92697–3100, USA

Summary

Author for correspondence:

Claudia I. Czimczik

Tel: +1 949 824 1474

Fax: +1 949 824 3874

Email: czimczik@uci.edu

Received: 21 September 2004

Accepted: 16 November 2004

- Here, we present a new *in-situ* method to study the uptake of amino acids by soil fungi.
- We injected ¹⁴C-labeled glycine into a marshland soil and measured the rate and the ¹⁴C signature of CO₂ respired from sporocarps of *Pholiota terrestris* over 53.5 h and 2 m. We also determined the incorporation of glycine-C into sporocarp tissue. The ¹⁴C signature of the CO₂ and tissue was quantified by accelerator mass spectrometry.
- After the label application, the rate of CO₂ flux and its ¹⁴C signature from chambers with sporocarps were significantly higher than from chambers without sporocarps, and then declined with time. Postlabel, the ¹⁴C signature of the sporocarp tissue increased by 35%.
- We show that this approach can be used to study below-ground food webs on an hourly time-scale while minimizing the perturbation of competitive relationships among soil microorganisms and between plants and soil microorganisms.
- Additionally we show that care must be taken to avoid confounding effects of sporocarp senescence on rates and radiocarbon signatures of respired CO₂.

Key words: plant–microbial interactions, radiocarbon, saprotrophic fungi, soil respiration, sporocarp.

New Phytologist (2005) doi: 10.1111/j.1469-8137.2005.01326.x

© *New Phytologist* (2005)

Introduction

In most terrestrial ecosystems, nitrogen (N) availability regulates species composition and biomass production (Vitousek & Howarth, 1991). Most research on microbe- and plant-available N has focused on the inorganic N compounds ammonium and nitrate.

In soils, *c.* 40% of N is present as organic N in proteinaceous material (amino acids, peptides, and proteins), 35% as heterocyclic compounds (e.g. nucleic acids), 5–6% as amino sugars (D-glucosamine and D-galactosamine), and 19% as NH₃ (Schulten & Schnitzer, 1998). Only a small fraction of the organic N is dissolved in the soil solution as free amino acids. Microbes can absorb free amino acids efficiently from the soil solution, as can plants in many families and with every possible mycorrhizal status (Lipson & Näsholm, 2001). Free

amino acids are produced during the hydrolysis of proteins and peptides by extracellular enzymes of microorganisms. Amino acids can also be released from bacterial cells or plant roots by excretion or during lysis of cells, for example during drying-rewetting or freeze-thaw events of soils. To better understand the dynamics of organic N in soils, we used soil respiration chambers to follow the transformation and transport of a radiocarbon (¹⁴C) labeled amino acid in one species of decomposer fungus under field conditions.

We injected ¹⁴C-labeled glycine into a marshland soil and tracked the release of that isotope in CO₂ respired by sporocarps of *Pholiota terrestris* over a timeline spanning 53.5 h and over a spatial scale spanning 2 m. We determined the extent to which carbon (C) derived from the glycine was incorporated into sporocarp tissue. By focusing on sporocarps, which can be identified to species, we could tie function (i.e. glycine transformation)

to fungal identity. By collecting respired CO_2 , which is a non-destructive technique, we could return repeatedly to the same sporocarps and measure the rates at which they respired the glycine-C. An additional advantage to our approach is that we used accelerator mass spectrometry to assess ^{14}C signatures in CO_2 and sporocarp tissue. This method is more sensitive than liquid scintillation counting or radiography, and it allowed us to apply minimal amounts of labeled glycine to the soil (0.175 mg glycine-C to be tracked over 2 m). Our intent was to minimize perturbations of competition among soil organisms and to avoid any possible 'priming' effects. We present our results as a proof-of-method that could potentially be used with other systems and substrates. We note that over time spans of days the phenology of sporocarps complicates the interpretation of the results.

Materials and Methods

We studied the uptake of ^{14}C labeled glycine by fungi in the San Joaquin Freshwater Marsh Reserve, located on the campus of the University of California Irvine (CA, USA). The vegetation consisted of black willow (*Salix gooddingii* BALL.) and alder (*Alnus* spec.) with grass in the understorey. The sporocarps were a 2-m diameter cluster of the wood decay fungus *Pholiota terrestris* OVERHOLTS (*Strophariaceae*).

We applied 0.175 mg glycine-C at 2 cm soil depth in one location amidst the cluster of sporocarps (Fig. 1). The ^{14}C glycine (Moravek Biochemicals, catalog # MC 163) was labeled at all C positions and diluted to *c.* 10 000–100 000‰ (136.5 μg glycine mL^{-1} in deionized water). At this level, the radioactivity is below levels that are regulated – the total added radioactivity in 0.175 mg glycine with an activity of 10–100 times Modern (10 000–100 000 mL^{-1}) is only 0.3–3 nCi. The glycine label was chosen because it is one of the more abundant amino acids in soil (Senwo & Tabatabai, 1998).

To track the ^{14}C label from glycine to CO_2 respired from the sporocarps, we measured the rate of CO_2 efflux and its ^{14}C signatures from the soil surface with sporocarps and without sporocarps. We sampled at three pairs of locations along a

linear transect from a willow tree towards an unpaved road, with location 1 being closest to the tree (Fig. 1). At each location we determined the rate of CO_2 efflux from the soil surface by placing a PVC chamber lid of 26-cm inner diameter with a tubing inlet and outlet on the chamber top on the soil surface. A sand-filled bag was placed around the perimeter of the chamber lid at its junction with the soil surface, to prevent diffusion of outside air into the chamber. We circulated the air in the chamber through a LI-800 infrared gas analyzer (Licor, Lincoln, NB, USA) for 3–8 min at 0.5 l min^{-1} and recorded the rate of change of CO_2 in the chamber headspace with a LI-1400 data logger. The rate of respired CO_2 was calculated as described in Borken *et al.* (2002). After measuring the CO_2 flux, we closed the tubing on the chamber lid and let CO_2 accumulate within the chamber for 10 min. We sampled the CO_2 in the chamber by pumping the air from the chamber through Drierite to an activated molecular sieve 13X trap that quantitatively removes CO_2 , then back to the chamber for 10 min at 0.5 l min^{-1} . We also collected ambient air *c.* 100 m upwind from the labeled site by flushing air through Drierite to a molecular sieve trap for 30 min at 0.5 l min^{-1} . Gas samples were taken 19 h before the label application, and 1 h, 5 h, 28.5, and 53.5 h after the label application. After each sampling we removed the chamber lids and sandbags from the transect. The weather was stable during the experiment, with a mean daily temperature of 17°C and no precipitation.

To isolate the CO_2 from the gas samples, we connected the molecular sieve traps to a vacuum line. The traps were heated to 650°C for 45 min. We froze out water in a glass trap cooled by ethanol/dry ice and CO_2 in a glass trap cooled by liquid N. Then, *c.* 1 mg C was frozen and sealed into an evacuated 9 mm Pyrex tube. This tube contained 25 mg Zn powder and 17 mg TiH_2 powder at the bottom. Approximately 2.5 cm above the bottom, we suspended a 6 mm Pyrex tube containing 5 mg Cobalt powder. Both tubes were prebaked for 3 h at 500°C and 4 h at 550°C . The CO_2 was converted to graphite, Ti, H_2O , and ZnO with Co acting as a catalyst for 3 h at 500°C and 4 h at 550°C .

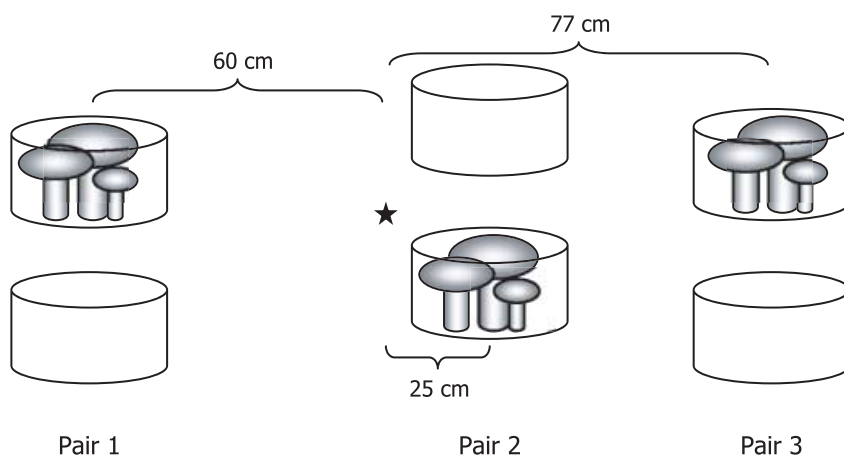

Fig. 1 Locations of label injection point and paired chambers. Each pair consisted of a chamber with sporocarps and a chamber without sporocarps. The star denotes injection point of ^{14}C -labeled glycine.

Near the location of the soil chambers we sampled sporocarps and roots (2 mm diameter or less, not separated between live and dead) 20 h before the label and 93.5 h after the label. The roots were washed three times in deionized water, and then soaked in 1 mmol KCl for 20 min to remove any label absorbed onto the root surface. After a final rinse in deionized water, they were dried for 3 d at 60°C. The sporocarps were also dried for 3 d at 60°C. The solid samples were combusted to CO₂ in evacuated, prebaked, 6 mm quartz tubes with 0.5 mg CuO powder for 2 h at 900°C. The resulting CO₂ was purified and catalytically reduced to graphite as described for the gas samples above. The radiocarbon content of the graphite was measured using accelerator mass spectrometry (NEC 0.5 mV 1.5SDH-2 AMS system) at the Keck-CCAMS facility of UCI. The Instrumental error for Δ¹⁴C was 2.5 ± 0.5‰.

We calculated the contribution of the sporocarps in each chamber to the soil respiration for each sampling time by using a mass balance approach:

$$[\text{CO}_2]_{\text{SC}} = f[\text{CO}_2]_{\text{NSC}} + (1 - f)[\text{CO}_2]_{\text{S}} \quad \text{Eqn 1}$$

$$(1 - f) = 1 - \frac{[\text{CO}_2]_{\text{NSC}}}{[\text{CO}_2]_{\text{SC}} + [\text{CO}_2]_{\text{NSC}}} \quad \text{Eqn 2}$$

$$\Delta^{14}\text{C}_\text{S} = \frac{\Delta^{14}\text{C}_\text{SC} - f\Delta^{14}\text{C}_\text{NSC}}{1 - f} \quad \text{Eqn 3}$$

where [CO₂] is the CO₂ concentration and Δ¹⁴C is the radiocarbon signature of the CO₂ respired in chambers with sporocarps (SC), chambers without sporocarps (NSC), and from the sporocarps in a chamber (S). Variable (*f*) is the fraction of CO₂ respired from the soil surface in the absence of sporocarps; (1 - *f*) is the fraction of CO₂ respired from the sporocarps. Variable (1 - *f*) was calculated using the CO₂

concentrations in each chamber pair 100 s after we started the flux measurement. We assumed that the CO₂ in the chamber was mainly derived from soil respiration and CO₂ from ambient air contributed little. The CO₂ concentration increased during the flux measurement from *c.* 380 ppm to > 1000 ppm in the chambers with sporocarps and reached 700–800 ppm in the chambers without sporocarps.

Results

CO₂ efflux from the chambers with sporocarps was highest 1 h after the label was applied and declined over time (Fig. 2). Between 1 and 28.5 h after the labeling, CO₂ effluxes from chambers with sporocarps (724.5 ± 76 mg C m⁻² h⁻¹) were significantly higher (*P* < 0.01) than from chambers without sporocarps (389.1 ± 30 mg C m⁻² h⁻¹). Before and 53.5 h after the labeling CO₂ effluxes from chambers with sporocarps and without sporocarps were similar. The mass balance calculation (Eqn 1) suggests that the proportion of CO₂ respired from the sporocarps at 1–28.5 h after labeling was *c.* 20–30% of the total CO₂-efflux in the chambers with sporocarps (Table 1). However, the equation could only be solved for this time interval when the CO₂ concentration in chambers with sporocarps was higher than in chambers without sporocarps (Fig. 2).

The ¹⁴C signature of the CO₂ respired from chambers with sporocarps was higher than that of chambers without sporocarps, except 53.5 h after the label application (Fig. 3). These findings were significant at 1 and 5 h after the label application (Table 2). In addition, the ¹⁴C signature of the CO₂ respired from the chambers with sporocarps changed significantly over time after the label was applied (Table 2). The ¹⁴C signature increased by *c.* 30‰ 1 h after the label was applied and then decreased by 5–20‰ with time. 53.5 h after the

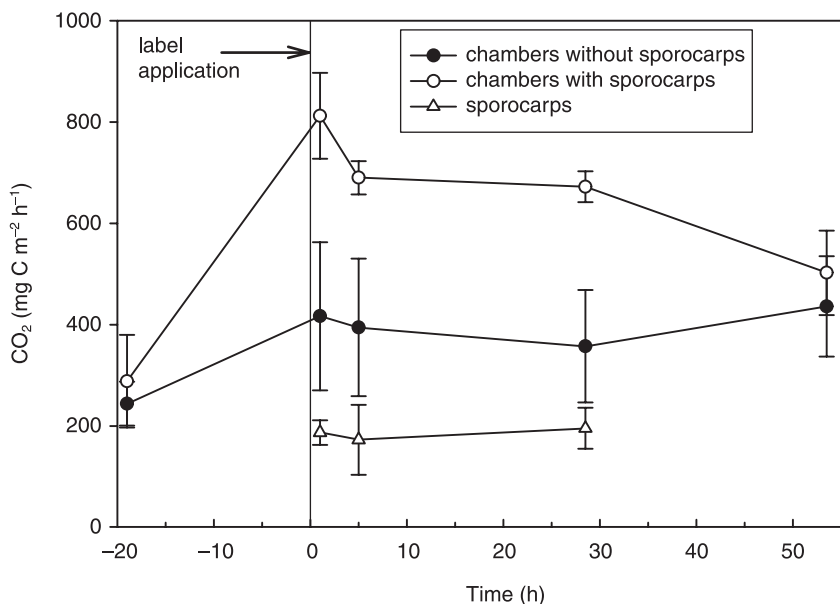
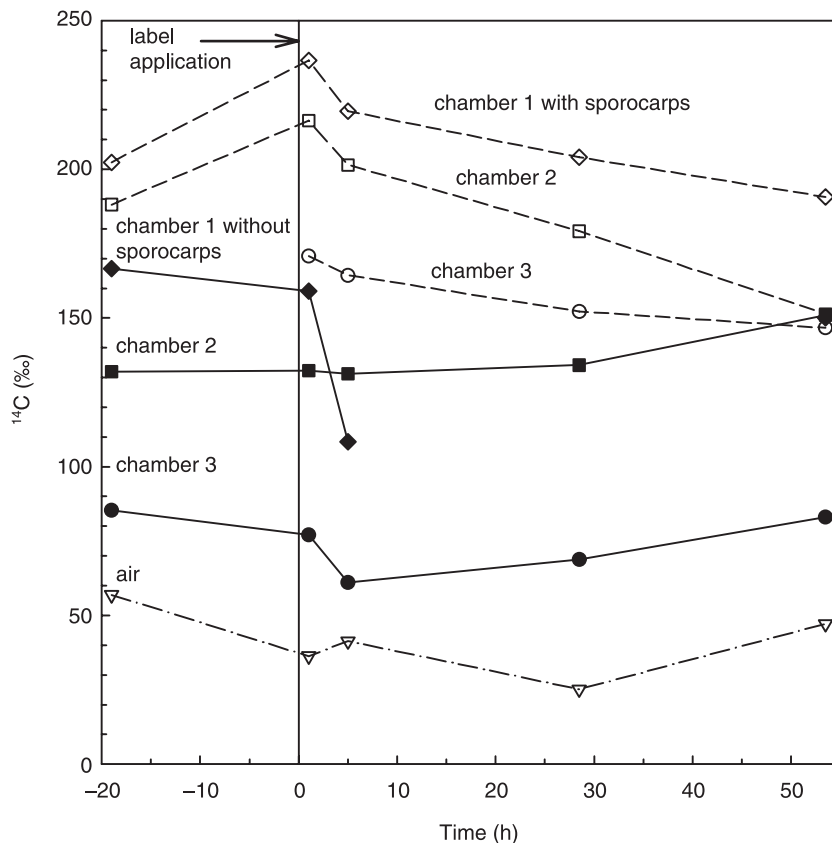

Fig. 2 Rate of CO₂ respired from the soil surface from chambers with and without sporocarps and estimated CO₂-efflux from sporocarps within the chambers (error bars indicate standard error).

Table 1 The radiocarbon signature of root and sporocarp tissue and of sporocarp-respired CO₂

Time since label (h)	Roots $\Delta^{14}\text{C}$ of bulk tissue (‰)	<i>n</i>	Sporocarps $\Delta^{14}\text{C}$ of bulk tissue (‰)	<i>n</i>	Estimated $\Delta^{14}\text{C}$ of respired CO ₂ from sporocarps (‰)	Estimated contribution of sporocarps to total CO ₂ efflux (%)	<i>n</i>
Pre-label -20	78.2 (9)	2	216.8	1			
Post-label 1					500.2 (57)	23 (3)	3
5					583.6 (228)	25 (10)	2
28.5					320.2 (15)	29 (6)	2
93.5	84.6 (7)	3	251.8 (17)	3			

(SE in parentheses).

**Fig. 3** ^{14}C signature of soil respired CO₂ measured in the three chamber pairs and of ambient air before the label was added and with time after the label. Open symbols and dotted lines indicate chambers with sporocarps; closed symbols and solid lines, chambers without sporocarps. Pair 1, diamonds; pair 2, squares; pair 3, circles.

label, the ^{14}C signature of the respired CO₂ was lower than that before the labeling. By contrast, the ^{14}C signature of CO₂ from chambers without sporocarps did not change significantly with time after the label was applied (Table 2). The ^{14}C signature of the respired CO₂ in all chambers was always higher than that of the ambient air (Fig. 3).

The ^{14}C signature of the sporocarp-respired CO₂ (Eqn 3) was only calculated if the flux contribution of the sporocarps was larger than 10% of the total flux (1–28.5 h after labeling). The sporocarp ^{14}C -signature increased dramatically until 5 h after the labeling (Table 1) and was much higher than that of the soil-respired CO₂ (Fig. 3). In addition, after the

label was added the ^{14}C signature of the sporocarp tissue increased by 35‰, while that of the root tissue did not change (Table 1).

In most cases, chambers without sporocarps had lower CO₂ effluxes and higher variability in CO₂ efflux and ^{14}C signatures, than did chambers with sporocarps, potentially owing to a higher proportion of ambient air in the chambers without sporocarps. We note that the $\delta^{13}\text{C}$ signature of the ambient air was $-9.7 \pm 0.5\text{‰}$. The low $\delta^{13}\text{C}$ and $\Delta^{14}\text{C}$ signature of the ambient air and its high variation can be explained by changes in the contribution of ^{14}C -depleted CO₂ produced from fossil fuels by nearby traffic. This

Table 2 Statistical results of variation in $\Delta^{14}\text{C}$

Paired <i>t</i>-test, chambers with sporocarps vs chambers without sporocarps			
Time since label (h)	<i>t</i>	Degrees of freedom	<i>P</i> -value
-19	-4.489	1	0.140
1	-18.033	2	0.003
5	-7.562	2	0.017
28.5	-3.344	1	0.185
53.5	-1.889	2	0.199
Repeated measures analysis of variance			
Factor	<i>F</i> -ratio	Degrees of freedom	<i>P</i> -value
Presence/absence of sporocarps	8.163	1,2	0.104
Time	5.806	4,4	0.017
Time \times sporocarps	14.868	4,8	0.001

contribution varies with changes in traffic density, wind speed and direction. The $\delta^{13}\text{C}$ value of the CO_2 sampled from the chambers with and without sporocarps was $-19.2 \pm 2.2\%$. The CO_2 in the chambers originated from ambient air and soil respiration. Before sampling, the CO_2 concentration in the chambers reached > 1000 ppm. This implies that the contributions of CO_2 from ambient air was $< 350/1000$ ppm, or $< 35\%$ in all chambers, and that the $\delta^{13}\text{C}$ of the soil-respired CO_2 was -24% .

Discussion

We added only a small amount of labeled glycine to prevent any possible 'priming' effects. However, after the label was applied, we observed that the flux of respired CO_2 increased by *c.* $400 \text{ mg C m}^{-2} \text{ h}^{-1}$ from chambers with sporocarps and by *c.* $200 \text{ mg C m}^{-2} \text{ h}^{-1}$ from chambers without sporocarps. To sustain this increase in respiration over a 24-h period within an area of 1 m^2 would require the respiration of an additional 9.6 g C for the chambers with sporocarps or 4.8 g C for chambers without sporocarps. We added only 0.000175 g of labeled C to the soil. Although the addition of glycine could have stimulated fungal respiration the increases in CO_2 efflux cannot be fully explained by the added C. The higher respiration most likely resulted from changes in the phenology of the sporocarps (growth, maturation, and decay throughout the experiment) and the activity of the mycelia. The largest part of the fungal biomass contributing to the CO_2 -efflux from the soil surface is located below-ground. Changes in the activity of the mycelia could also have contributed to the increase of CO_2 -efflux in the chambers without sporocarps since fungal mycelia can extend below-ground for several meters from the nearest sporocarp (Kretzer *et al.*, 2004). Also, higher overall soil respiration could be caused by changes in root respiration of grass and trees or disturbance of the soil during the measurements.

Despite the high variability in the fluxes, the changes in the ^{14}C signature of the sporocarp-respired CO_2 together with the increase of the ^{14}C signature of the sporocarp tissue indicate

that the labeled glycine was taken up and metabolized by the fungi and released from their sporocarps within 5 h. The label was even detected within the first hour in the CO_2 respired from sporocarps growing 60 cm from the injection point ('Location 2'). This indicates that the labeled C could be transported quickly over a relatively large area, potentially through fungal rhizomorphs. The rapid decrease in the ^{14}C value indicates that most of the label was respired shortly after it became available. This short response time is consistent with previous findings that smaller amino acids such as glycine are taken up and processed by organisms relatively quickly (Lipson *et al.*, 1999).

Laboratory-based studies have often used isotopic labels to examine the uptake, assimilation, or transformation of specific compounds by fungi (e.g. Kirk *et al.*, 1975; Finlay, 1992; Steffen *et al.*, 2002; Frey *et al.*, 2003; Hobbie *et al.*, 2003). Field-based applications are rare but critical; they incorporate complex biotic and abiotic interactions such as competition among microbes or between microbes and plants. *In situ* measurements have included incorporation of isotopically labeled C into ergosterol, a compound primarily produced by fungi (Suberkropp & Weyers, 1996). Carbon has also been tracked between 'donor' and 'recipient' plants via mycorrhizal fungi (Simard *et al.*, 1997). The isolation of fungal tissues or signal compounds from soils has posed a logistical challenge in field studies. By contrast, sporocarps can serve as a conduit of the tracer from below-ground mycelia to more easily manageable and identifiable surface structures. However, one drawback is that sporocarps are ephemeral and only represent a portion of fungal biomass.

In many tracer studies the use of the stable ^{13}C isotope as a tracer should be chosen over ^{14}C due to easier handling and much lower costs. However, ^{14}C can be very useful when operating with very small amounts of quickly metabolized compounds. Even if we had added pure ^{13}C glycine the change in the $\delta^{13}\text{C}$ ratio of the respired CO_2 would have been within the range of fractionation during photosynthetic uptake which is reflected in the $\delta^{13}\text{C}$ ratio of soil respiration (Fig. 4). By contrast, the signal from the ^{14}C label is outside natural variation and is visible over a longer time span.

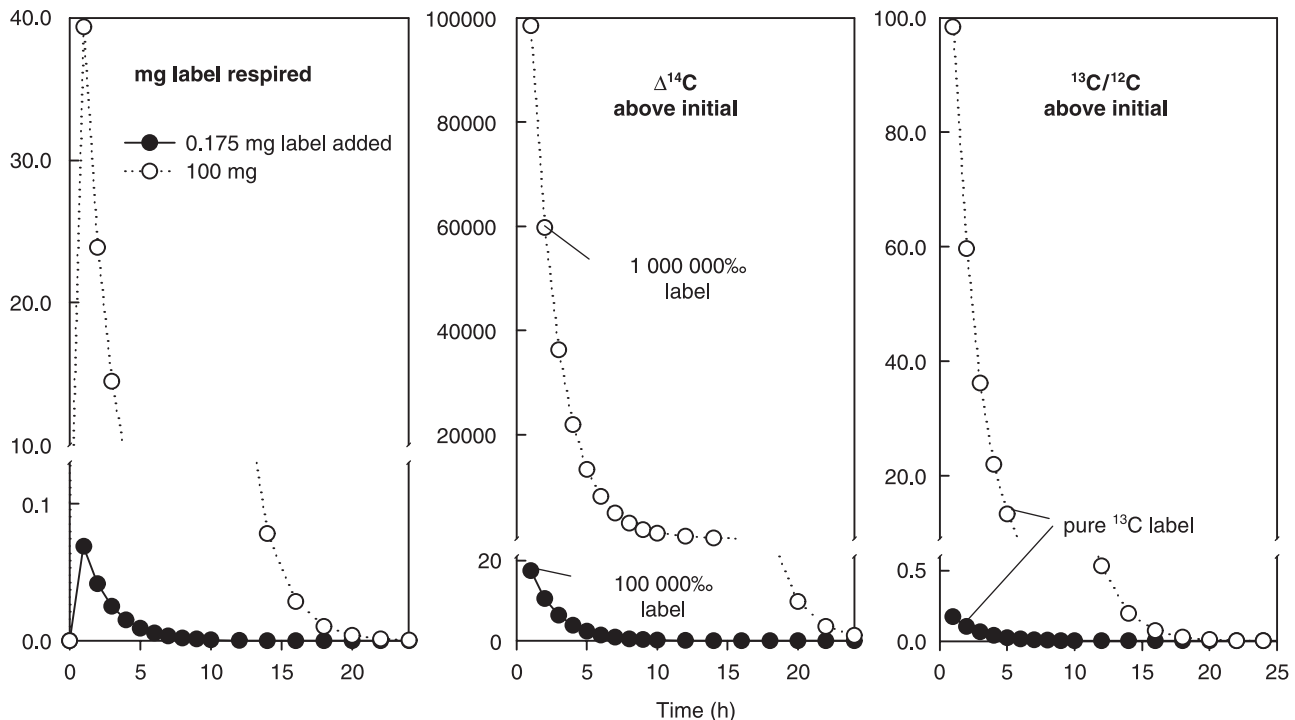

Fig. 4 Signal of a label of 0.175 or 100 mg C of ^{14}C (100 000 or 1 000 000‰) or pure ^{13}C respired at a flux of $400 \text{ mg C m}^{-2} \text{ h}^{-1}$ and an e-folding time of 2; $\text{label}_{\text{respired}} = \text{label}_{\text{added}} - \text{label}_{\text{added}} \times e^{\left(-\frac{\text{time}}{2}\right)}$.

Our results suggest that the presence of saprotrophic sporocarps can significantly alter the rates of CO_2 respired from soils. In addition, growth, maturation, and decay of the sporocarps and mycelia might be coupled to changes in the composition of the ^{14}C signature of soil respired CO_2 . This should be considered in soil respiration studies. We show that small amounts of ^{14}C combined with chamber measurements can be used as a tracer to study the fate and dynamics of individual components of soil organic matter in below ground food webs under field conditions on an hourly resolution.

Acknowledgements

We thank KM Turner and X Xu for assistance in the field and laboratory. Funding sources were the Gary Comer Foundation (to SE Trumbore), National Science Foundation Carbon Cycle Program in the Geosciences Directorate (to SE Trumbore) and NSF Ecosystems grant (to KK Treseder, DEB-0430111).

References

- Borken W, Xu Y-J, Davidson EA, Beese F. 2002. Site and temporal variation of soil respiration in European beech, Norway spruce, and Scots pine forests. *Global Change Biology* 8: 1205. doi: 10.1046/j.1365-2486.2002.00547.x.
- Finlay RD. 1992. Uptake and translocation of nutrients by ectomycorrhizal fungal mycelia. In: Read DJ, ed. *Mycorrhizas in Ecosystems*. Oxon, UK: CAB International. 91–97.
- Frey SD, Six J, Elliott ET. 2003. Reciprocal transfer of carbon and nitrogen by decomposer fungi at the soil–litter interface. *Soil Biology and Biochemistry* 35: 1001–1004.
- Hobbie EA, Watrud LS, Maggard S, Shiroyama T, Rygielwicz PT. 2003. Carbohydrate use and assimilation by litter and soil fungi assessed by carbon isotopes and BIOLOG (R) assays. *Soil Biology and Biochemistry* 35: 303–311.
- Kirk TK, Connors WJ, Bleam RD, Hackett WF, Zeikus JG. 1975. Preparation and microbial decomposition of synthetic [^{14}C]lignins. *Proceedings of the National Academy of Sciences, USA* 72: 2515–2519.
- Kretzer AM, Dunham S, Molina R, Spatafora JW. 2004. Microsatellite markers reveal the below ground distribution of genets in two species of Rhizopogon forming tuberculate ectomycorrhizas on Douglas fir. *New Phytologist*. doi: 10.1046/j.1469-8137.2003.00915.x.
- Lipson D, Näsholm T. 2001. The unexpected versatility of plants: organic nitrogen use and availability in terrestrial ecosystems. *Oecologia*. doi: 10.1007/s004420100693.
- Lipson DA, Raab TK, Schmidt SK, Monson RK. 1999. Variation in competitive abilities of plants and microbes for specific amino acids. *Biology and Fertility of Soils* 29: 257–261.
- Schulten H-R, Schnitzer M. 1998. The chemistry of soil organic nitrogen: a review. *Biology and Fertility of Soils* 26: 1–15.
- Senwo ZN, Tabatabai MA. 1998. Amino acid composition of soil organic matter. *Biology and Fertility of Soils* 26: 235–242.
- Simard SW, Perry DA, Jones MD, Myrold DD, Durall DM, Molina R. 1997. Net transfer of carbon between ectomycorrhizal tree species in the field. *Nature* 388: 579–582.
- Steffen KT, Hatakka A, Hofrichter M. 2002. Degradation of humic acids by the litter-decomposing basidiomycete *Collybia dryophila*. *Applied and Environmental Microbiology* 68: 3442–3448.
- Suberkropp K, Weyers H. 1996. Application of fungal and bacterial production methodologies to decomposing leaves in streams. *Applied and Environmental Microbiology* 62: 1610–1615.
- Vitousek PM, Howarth RW. 1991. Nitrogen limitation on land and in the sea: how can it occur? *Biogeochemistry* 13: 87–115.